

Pole-changing motors SIMOTICS GP 1LE1 Standard Motors

Self-ventilated motors · Aluminum series 1LE1011/1LE1012 for square-law load torque

Selection and ordering data

P _{ra} ted1, ted2		P _{ra} 50 Hz	Frame size	Operating values at rated output for N1								Operating values at rated output for N2								Aluminum series	m _{IM B3} J	Torque class
n _{ra}	T _{ra}	η _{ra}	cos φ _{ra}	I _{ra}	T _{LR} /T _{ra}	I _{LR} /I _{ra}	T _B /T _{ra}	n _{ra}	T _{ra}	η _{ra}	cos φ _{ra}	I _{ra}	T _{LR} /T _{ra}	I _{LR} /I _{ra}	T _B /T _{ra}	1LE1011 – One winding						
50 Hz	50 Hz	50 Hz	ted1, ted1, ted1, 4/4	50 Hz	ted1, 50 Hz	ted1, 50 Hz	ted1, 50 Hz	50 Hz	50 Hz	50 Hz	ted2, ted2, ted2, 4/4	50 Hz	ted2, 50 Hz	ted2, 50 Hz	ted2, 50 Hz	1LE1012 – Two windings pole-changing for square-law load torque						
kW	kW	FS	rpm	Nm	%	A		rpm	Nm	%	A					▲ New		CL				
<ul style="list-style-type: none"> • Cooling: self-ventilated (IC411) • Line operation: double pole-changing for square-law load torque, e.g. for driving fans • Insulation: thermal class 155 (temperature class F), IP55 degree of protection, utilization in accordance with thermal class 130 (temperature class B) 																						
4/2-pole: 1500/3000 rpm at 50 Hz with one winding connected in Dahlander circuit																						
1500 rpm	3000 rpm		1500 rpm					3000 rpm														
0.65	2.4	100 L	1415	4.4	75	0.86	1.45	1.6	4.1	1.8	2800	8.2	70	0.88	5.6	1.8	4.2	1.8	1LE1011-1AP4	18	0.0059	13
0.8	3.1	100 L	1435	5.3	79	0.85	1.72	1.9	5.2	2.8	2840	10.4	77.3	0.9	6.4	2.1	5.2	2.8	1LE1011-1AP5	22	0.0078	13
1.1	4.4	112 M	1455	7.2	83.4	0.85	2.25	2.2	6.1	2.5	2885	14.6	80.8	0.92	8.5	2.1	6.4	2.5	1LE1011-1BP2	27	0.01	13
1.45	5.9	132 S	1460	9.5	84	0.84	2.95	1.6	5.8	2.8	2875	19.6	80	0.89	12.0	1.8	5.6	2.8	1LE1011-1CP0	38	0.019	13
2.0	8.0	132 M	1455	13.1	85	0.85	4.00	1.8	5.6	2.8	2880	26.5	82	0.92	15.3	1.8	6.3	2.8	1LE1011-1CP2	44	0.024	13
2.9	11.5	160 M	1465	18.9	86.5	0.86	5.6	1.8	5.9	2.9	2870	38.3	82	0.92	22.0	1.8	6	2.9	1LE1011-1DP2	62	0.044	13
4.3	16	160 L	1455	28.2	87	0.85	8.4	1.6	6	2.3	2920	52.3	86	0.94	28.5	1.9	7.1	2.3	1LE1011-1DP6	85	0.068	13
6/4-pole: 1000/1500 rpm at 50 Hz with two windings																						
1000 rpm	1500 rpm		1000 rpm					1500 rpm														
0.6	1.7	100 L	970	5.9	55.5	0.62	2.50	1.7	3.4	2.7	1435	11.3	76.2	0.83	3.90	1.8	4.6	2.7	1LE1012-1AQ4	18	0.0059	10
0.8	2.1	100 L	955	8	64.2	0.77	2.35	1.2	3.4	2	1435	14	78.4	0.84	4.60	2	5.4	2	1LE1012-1AQ5	22	0.0078	10
0.9	3.0	112 M	975	8.8	64.7	0.66	3.05	1.6	3.9	2.5	1455	19.7	81.4	0.78	6.8	2.1	6.4	2.5	1LE1012-1BQ2	27	0.01	13
1.2	3.9	132 S	980	11.7	72.3	0.7	3.40	1.4	4.6	2.5	1455	25.6	83.1	0.83	8.2	1.5	5.7	2.5	1LE1012-1CQ0	38	0.019	10
1.7	5.4	132 M	980	16.6	74.1	0.71	4.65	1.7	5	2.5	1465	35.2	85.9	0.82	11.1	2	6.9	2.5	1LE1012-1CQ2	44	0.024	10
2.5	7.2	160 M	985	24.2	77.7	0.71	6.5	1.5	4.7	2.6	1470	46.8	86.9	0.85	14.1	1.8	6.3	2.6	1LE1012-1DQ2	62	0.044	10
3.7	12.0	160 L	985	35.9	82.4	0.69	9.4	2.3	6.2	3.5	1475	77.7	87.9	0.8	24.5	2.1	7.5	3.5	1LE1012-1DQ4	73	0.059	10
6.5	19	180 L	985	63	81.0	0.7	16.5	1.8	5.5	2.7	1475	123	0.9	0.8	38.0	2.5	8.1	3.7	▲ 1LE1012-1EQ4	132	0.13	10
9.5	26	200 L	985	92	84.5	0.7	23.0	2.3	6.5	2.8	1475	168	0.91	0.8	52	2.3	7.5	3.4	▲ 1LE1012-2AQ5	173	0.20	10
Voltagess																						
50 Hz		230 V	No. of poles		4/2, 6/4	Frame size		100 L ... 200 L	Motor type		1LE101-1A ... -2A	Version		Standard	2	2	Order code(s)		-			
50 Hz		400 V	4/2, 6/4		100 L ... 200 L		1LE101-1A ... -2A		Standard		3	4	-		-		-		-			
50 Hz		500 V	4/2, 6/4		100 L ... 200 L		1LE101-1A ... -2A		Without add. charge		4	0	-		-		-		-			
50 Hz		690 V	4/2, 6/4		100 L ... 200 L		1LE101-1A ... -2A		Without add. charge		4	7	-		-		-		-			
Further voltages ¹⁾		For price information, code numbers, order codes and descriptions, see from Page 2/59																				
Types of construction																						
Without flange		IM B3 ²⁾		4/2, 6/4		100 L ... 200 L		1LE101-1A ... -2A		Standard		A		-		-		-		-		
With flange		IM B5 ²⁾		4/2, 6/4		100 L ... 200 L		1LE101-1A ... -2A		With additional charge		F		-		-		-		-		
With standard flange		IM B14 ²⁾		4/2, 6/4		100 L ... 160 L		1LE101-1A ... -2A		With additional charge		K		-		-		-		-		
Further types of construction		For price information, code letters and descriptions, see from Page 2/62																				
Motor protection																						
Without		4/2, 6/4		100 L ... 200 L		1LE101-1A ... -2A		Standard		A		-		-		-		-		-		
PTC thermistor with 3 temperature sensors		4/2, 6/4		100 L ... 200 L		1LE101-1A ... -2A		With additional charge		B		-		-		-		-		-		
Further motor protection		For price information, code letters and descriptions, see from Page 2/70																				
Terminal box position																						
Terminal box at top		4/2, 6/4		100 L ... 200 L		1LE101-1A ... -2A		Standard		4		-		-		-		-		-		
Further terminal box positions		For price information, code numbers and descriptions, see from Page 2/72																				
Special versions																						
Options		For price information, order codes and descriptions, see from Page 2/74															1LE101-...-Z		...+...+...			

Note: Pole-changing motors (4-/2-pole) do not comply with the vibration values stipulated in IEC 60034-14 when rigidly installed (see also Page 1/46).

¹⁾ Operating values at rated output for 60 Hz are stored in the Drive Technology (DT) Configurator.
²⁾ Types derived from IM B3 (IM B6/7/8, IM V6 and IM V5), from IM B5 (IM V3 and IM V1) and from IM B14 (IM V19 and IM V18) are possible, provided that no requirements exist for condensation drainage holes (H03) and stamping of the type on the rating plate. The basic type IM B3, IM B5 or IM B14 is stamped as standard on the rating plate. When ordering with condensation drainage holes (H03), the type must be specified.

Pole-changing motors

SIMOTICS GP 1LE1 Standard Motors

Self-ventilated motors · Aluminum series 1LE1011/1LE1012 for square-law load torque

Selection and ordering data (continued)

P _{ra} -ted1, 50 Hz		P _{ra} -ted2, 50 Hz		Frame size	Operating values at rated output for N1								Operating values at rated output for N2								Aluminum series 1LE1011 – One winding Pole-changing motor for square-law load torque	m _{MM B3} J	Torque class
n _{ra} -ted1, 50 Hz	T _{ra} -ted1, 50 Hz	η _{ra} -ted1, 50 Hz	cos φ _{ra} -ted1, 50 Hz		I _{ra} -ted1, 50 Hz	T _{LR} /I _{ra} -ted1, 50 Hz	I _{LR} /I _{ra} -ted1, 50 Hz	T _B /I _{ra} -ted1, 50 Hz	n _{ra} -ted2, 50 Hz	T _{ra} -ted2, 50 Hz	η _{ra} -ted2, 50 Hz	cos φ _{ra} -ted2, 50 Hz	I _{ra} -ted2, 50 Hz	T _{LR} /I _{ra} -ted2, 50 Hz	I _{LR} /I _{ra} -ted2, 50 Hz	T _B /I _{ra} -ted2, 50 Hz							
50 Hz	50 Hz	50 Hz	50 Hz		4/4	50 Hz, 400 V	50 Hz	50 Hz	50 Hz	50 Hz	4/4	50 Hz, 400 V	50 Hz	50 Hz	50 Hz	4/4	50 Hz, 400 V	50 Hz	50 Hz	50 Hz	Article No.	▲ New	CL
kW	kW	FS	rpm	Nm	%	A						rpm	Nm	%	A								
<ul style="list-style-type: none"> • Cooling: self-ventilated (IC411) • Line operation: double pole-changing for square-law load torque, e.g. for driving fans • Insulation: thermal class 155 (temperature class F), IP55 degree of protection, utilization in accordance with thermal class 130 (temperature class B) 																							
8/4-pole: 750/1500 rpm at 50 Hz with one winding connected in Dahlander circuit																							
750 rpm	1500 rpm		750 rpm									1500 rpm											
0.5	2.0	100 L	720	6.6	52	0.5	2.80	1.3	3.3	3.4	1440	13.3	82	0.79	4.45	3	7.5	3.4		1LE1011-1AR4	22	0.0078	7
0.65	2.5	100 L	715	8.7	56	0.58	2.90	1	3.2	2.6	1425	16.8	81	0.84	5.3	2.3	6.3	2.6		1LE1011-1AR5	22	0.0078	7
0.9	3.6	112 M	715	12	56	0.57	4.05	1	2.8	2.1	1430	24	82	0.84	7.5	1.9	5.6	2.1		1LE1011-1BR2	27	0.01	7
1.1	4.7	132 S	730	14.4	62	0.54	4.75	1	3.2	2.2	1430	31.4	82	0.86	9.6	1.7	5.2	2.2		1LE1011-1CR0	38	0.019	7
1.4	6.4	132 M	730	18.3	67.5	0.52	5.8	1.1	3.5	2.3	1440	42.4	84.5	0.87	12.6	1.9	5.7	2.3		1LE1011-1CR2	44	0.024	7
2.2	9.5	160 M	730	28.8	80.6	0.63	6.3	1.5	4	2.5	1465	61.9	86.1	0.84	19.0	2	6.3	2.5		1LE1011-1DR2	62	0.044	10
3.3	14	160 L	735	42.9	81.4	0.56	10.4	2.5	4.8	3.3	1475	90.6	85.8	0.73	32.5	2.5	7.2	3.3		1LE1011-1DR4	73	0.056	16
4.5	16	180 M	730	59	79.3	0.59	13.9	1.4	3.8	2.3	1470	104	84.6	0.83	33.0	1.4	7	2.9		▲ 1LE1011-1ER2	128	0.12	10
5	18.5	180 L	730	65	78.3	0.6	15.4	1.5	3.8	2.1	1470	120	86.6	0.83	37.0	2.3	7	2.7		▲ 1LE1011-1ER4	132	0.13	10
7.5	28	200 L	735	97	85.0	0.6	21.0	1.7	4	2.1	1475	181	90.5	0.85	53	2.7	7.4	3.1		▲ 1LE1011-2AR5	173	0.20	10
Ordering code structure																							
Voltages		No. of poles	Frame size	Motor type	Version																	Order code(s)	
50 Hz	230 V	8/4	100 L ... 200 L	1LE101-1A ... -2A	Standard	2	2															-	
50 Hz	400 V	8/4	100 L ... 200 L	1LE101-1A ... -2A	Standard	3	4															-	
50 Hz	500 V	8/4	100 L ... 200 L	1LE101-1A ... -2A	Without add. charge	4	0															-	
50 Hz	690 V	8/4	100 L ... 200 L	1LE101-1A ... -2A	Without add. charge	4	7															-	
Further voltages ¹⁾		For price information, code numbers, order codes and descriptions, see from Page 2/59																					
Types of construction		No. of poles	Frame size	Motor type	Version																	Order code(s)	
Without flange		IM B3 ²⁾	8/4	100 L ... 200 L	1LE101-1A ... -2A	Standard	A															-	
With flange		IM B5 ²⁾	8/4	100 L ... 200 L	1LE101-1A ... -2A	With additional charge	F															-	
With standard flange		IM B14 ²⁾	8/4	100 L ... 160 L	1LE101-1A ... -2A	With additional charge	K															-	
Further types of construction		For price information, code letters and descriptions, see from Page 2/62																					
Motor protection		No. of poles	Frame size	Motor type	Version																	Order code(s)	
Without		8/4	100 L ... 200 L	1LE101-1A ... -2A	Standard	A																-	
PTC thermistor with 3 temperature sensors		8/4	100 L ... 200 L	1LE101-1A ... -2A	With additional charge	B																-	
Further motor protection		For price information, code letters and descriptions, see from Page 2/70																					
Terminal box position		No. of poles	Frame size	Motor type	Version																	Order code(s)	
Terminal box at top		8/4	100 L ... 200 L	1LE101-1A ... -2A	Standard	4																-	
Further terminal box positions		For price information, code numbers and descriptions, see from Page 2/72																					
Special versions																					Order code(s)		
Options		For price information, order codes and descriptions, see from Page 2/74																			1LE101-...-Z ...+...+...		

Note: Pole-changing motors (4-/2-pole) do not comply with the vibration values stipulated in IEC 60034-14 when rigidly installed (see also Page 1/46).

¹⁾ Operating values at rated output for 60 Hz are stored in the Drive Technology (DT) Configurator.

²⁾ Types derived from IM B3 (IM B6/7/8, IM V6 and IM V5), from IM B5 (IM V3 and IM V1) and from IM B14 (IM V19 and IM V18) are possible, provided that no requirements exist for condensation drainage holes (H03) and stamping of the type on the rating plate. The basic type IM B3, IM B5 or IM B14 is stamped as standard on the rating plate. When ordering with condensation drainage holes (H03), the type must be specified.

Supplements to article numbers and special versions

SIMOTICS GP 1LE1 Standard Motors

Voltages · Aluminum series 1LE1011, 1LE1012 – pole-changing

Selection and ordering data

Voltages	Voltage code 12th and 13th position of the Article No.	Additional identification code with order code and plain text if required	Motor category							
			Motor version	Motor type (alum.)	Motor type – frame size					
			Pole-changing	1LE1011 1LE1012	1LE1011 1LE1012					
			Motor version	Motor type	Frame size					
					100	112	132	160	180	200
1LE1...-...-...-... Order code										
Voltage at 50 Hz and 50 Hz output										
230 V	2	2	–	All	All	□	□	□	□	□
400 V	3	4	–	All	All	□	□	□	□	□
500 V	4	0	–	All	All	○	○	○	○	○
690 V	4	7	–	All	All	○	○	○	○	○
Voltage at 60 Hz and required output										
220 V; 50 Hz output	9	0	M5K	All	All	O. R.	O. R.	O. R.	O. R.	O. R.
220 V; 60 Hz output	9	0	M5C	All	All	O. R.	O. R.	O. R.	O. R.	O. R.
380 V; 50 Hz output	9	0	M5L	All	All	O. R.	O. R.	O. R.	O. R.	O. R.
380 V; 60 Hz output	9	0	M5D	All	All	O. R.	O. R.	O. R.	O. R.	O. R.
440 V; 50 Hz output	9	0	M5M	All	All	O. R.	O. R.	O. R.	O. R.	O. R.
440 V; 60 Hz output	9	0	M5E	All	All	O. R.	O. R.	O. R.	O. R.	O. R.
460 V; 50 Hz output	9	0	M5N	All	All	O. R.	O. R.	O. R.	O. R.	O. R.
460 V; 60 Hz output	9	0	M5F	All	All	O. R.	O. R.	O. R.	O. R.	O. R.
575 V; 50 Hz output	9	0	M5P	All	All	O. R.	O. R.	O. R.	O. R.	O. R.
575 V; 60 Hz output	9	0	M5G	All	All	O. R.	O. R.	O. R.	O. R.	O. R.
Non-standard voltage and/or frequencies										
Non-standard winding ¹⁾	9	0	M1Y • and customer specifications	All	All	✓	✓	✓	✓	✓

- Standard version
- Without additional charge
- This order code only determines the price of the version – Additional plain text is required.
- ✓ With additional charge
- O. R. Possible on request













¹⁾ Plain text must be specified in the order: Voltage between 200 and 690 V (voltages outside this range are available on request), frequency, circuit, for 60 Hz additionally required rated output in kW.

Supplements to article numbers and special versions

SIMOTICS GP 1LE1/1PC1 Standard Motors

Types of construction · Aluminum series 1LE10, 1PC10

Selection and ordering data







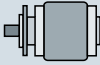

Types of construction	Type of construction letter	For types of construction with order code(s) Article No. with additional identification code -Z	Motor category		Motor type – frame size								
			Motor version	Motor type (alum.)	80	90	100	112	132	160	180	200	
			IE2 High Efficiency	1LE1001	1LE1001 ①								
				1PC1001		1PC1001 ②							
				1LE1041		1LE1041 APAC Line ③							
			IE3 Premium Efficiency	1LE1003	1LE1003 ④								
				1LE1043	1LE1043 APAC Line ⑤								
			IE4 Super Premium Efficiency	1LE1004		1LE1004 ⑥							
			IE1 Standard Efficiency	1LE1002		1LE1002 ⑦							
				1PC1002		1PC1002 ⑧							
			NEMA Energy Efficient	1LE1021		1LE1021 Eagle Line ⑨							
			NEMA Premium Efficient	1LE1023		1LE1023 Eagle Line ⑩							
Pole-changing	1LE1011		1LE1011 ⑪										
	1LE1012		1LE1012 ⑫										
1LE10 (-Z)		Motor version	Motor type	Frame size	80	90	100	112	132	160	180	200
1PC10 (-Z)	Order code											
Without flange													
IM B3 ^{1) 2) 3)}		A	-	All except ③ and ⑨		☐	☐	☐	☐	☐	☐	☐	☐
IM B6 ^{2) 3)}		T	-	All except ③ and ⑨		☐	☐	☐	☐	☐	☐	☐	☐
IM B7 ^{2) 3)}		U	-	All except ③ and ⑨		☐	☐	☐	☐	☐	☐	☐	☐
IM B8 ^{2) 3)}		V	-	All except ③ and ⑨		☐	☐	☐	☐	☐	☐	☐	☐
IM V6 ^{2) 3)}		D	-	All except ③ and ⑨		☐	☐	☐	☐	☐	☐	☐	☐
IM V5 without protective cover ^{2) 3)}		C	-	All except ③ and ⑨		☐	☐	☐	☐	☐	☐	☐	☐
IM V5 with protective cover ^{2) 3) 4) 5) 6)}		C	H00	All except ②, ③, ⑥, ⑨ and in combination with order code F90	✓	✓	✓	✓	✓	✓	✓	✓	✓
With flange						FF165	FF165	FF215	FF215	FF265	FF300	FF300	FF350
					Acc. to EN 50347	A 200	A 200	A 250	A 250	A 300	A 350	A 350	A 400
					Acc. to DIN 42948								
IM B5 ^{2) 7)}		F	-	All	All	✓	✓	✓	✓	✓	✓	✓	✓
IM V1 without protective cover ²⁾		G	-	All	All	✓	✓	✓	✓	✓	✓	✓	✓
IM V1 with protective cover ^{2) 4) 5) 6)}		G	H00	All except ②, ⑥ and in combination with order code F90		✓	✓	✓	✓	✓	✓	✓	✓
IM V3 ⁴⁾		H	-	All	All	✓	✓	✓	✓	✓	✓	✓	✓
IM B35 ³⁾		J	-	All except ③ and ⑨		✓	✓	✓	✓	✓	✓	✓	✓

For legends and footnotes, see Page 2/65.

Supplements to article numbers and special versions

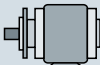
SIMOTICS GP 1LE1/1PC1 Standard Motors

Types of construction · Aluminum series 1LE10, 1PC10

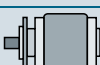
Types of construction	Type of construction letter	For types of construction with order code(s)	Motor category		Motor type – frame size								
			Motor version	Motor type (alum.)	80	90	100	112	132	160	180	200	
1LE10 (-Z) 1PC10 (-Z)		Article No. with additional identification code -Z Order code	IE2 High Efficiency	1LE1001 1PC1001	1LE1001 ①								
				1LE1041	1PC1001 ②								
				1LE1041 APAC Line ③									
			IE3 Premium Efficiency	1LE1003 1LE1043	1LE1003 ④								
				1LE1043 APAC Line ⑤									
			IE4 Super Premium Efficiency	1LE1004	1LE1004 ⑥								
			IE1 Standard Efficiency	1LE1002 1PC1002	1LE1002 ⑦								
				1PC1002 ⑧									
			NEMA Energy Efficient	1LE1021	1LE1021 Eagle Line ⑨								
			NEMA Premium Efficient	1LE1023	1LE1023 Eagle Line ⑩								
Pole-changing	1LE1011 1LE1012	1LE1011 ⑪											
	1LE1012 ⑫												
			Motor version	Motor type	Frame size								
					80	90	100	112	132	160	180	200	
With special flange next larger			Acc. to EN 50347 Acc. to DIN 42948		-	-	FF265	FF265	FF300	-	-	-	
					-	-	A 300	A 300	A 350	-	-	-	
IM B5 2) 7)		F	P01	All	All	-	-	✓	✓	✓	-	-	
IM V1 without protective cover 2)		G	P01	All	All	-	-	✓	✓	✓	-	-	
IM V1 with protective cover 2) 4) 5) 6)		G	P01+H00	All except ②, ⑩ and in combination with order code F90		-	-	✓	✓	✓	-	-	
IM V3 4)		H	P01	All	All	-	-	✓	✓	✓	-	-	
IM B35 3)		J	P01	All except ③ and ⑨		-	-	✓	✓	✓	-	-	
With special flange next smaller			Acc. to EN 50347 Acc. to DIN 42948		-	-	FF165	FF165	FF215	FF265	FF265	FF300	
					-	-	A 200	A 200	A 250	A 300	A 300	A 350	
IM B5 2) 7)		F	P02	All	All	-	-	O.R.	O.R.	O.R.	O.R.	O.R.	
IM V1 without protective cover 2)		G	P02	All	All	-	-	O.R.	O.R.	O.R.	O.R.	O.R.	
IM V1 with protective cover 2) 4) 5) 6)		G	P02+H00	All except ②, ⑩ and in combination with order code F90		-	-	O.R.	O.R.	O.R.	O.R.	O.R.	
IM V3 4)		H	P02	All	All	-	-	O.R.	O.R.	O.R.	O.R.	O.R.	
IM B35 3)		J	P02	All except ③ and ⑨		-	-	O.R.	O.R.	O.R.	O.R.	O.R.	









For legends and footnotes, see Page 2/65.

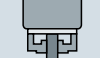

Supplements to article numbers and special versions

SIMOTICS GP 1LE1/1PC1 Standard Motors

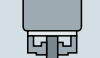



Types of construction · Aluminum series 1LE10, 1PC10

Types of construction	Type of construction letter 14th position of the Article No.	For types of construction with order code(s) Article No. with additional identification code -Z	Motor category		Motor type – frame size										
			Motor version	Motor type (alum.)	80	90	100	112	132	160	180	200			
			IE2 High Efficiency	1LE1001	1LE1001 ①										
				1PC1001		1PC1001 ②									
			IE3 Premium Efficiency	1LE1041	1LE1041 APAC Line ③										
				1LE1003	1LE1003 ④										
			IE4 Super Premium Efficiency	1LE1043	1LE1043 APAC Line ⑤										
				1LE1004	1LE1004 ⑥										
			IE1 Standard Efficiency	1LE1002	1LE1002 ⑦										
				1PC1002	1PC1002 ⑧										
			NEMA Energy Efficient	1LE1021	1LE1021 Eagle Line ⑨										
			NEMA Premium Efficient	1LE1023	1LE1023 Eagle Line ⑩										
Pole-changing	1LE1011	1LE1011 ⑪													
	1LE1012	1LE1012 ⑫													
1LE10 (-Z)		Motor version	Motor type	Frame size										
1PC10 (-Z)	Order code			80	90	100	112	132	160	180	200			
With standard flange			Acc. to EN 50347		FT100	FT115	FT130	FT130	FT165	FT215	-	-			
			Acc. to DIN 42948		C 120	C 140	C 160	C 160	C 200	C 250	-	-			
IM B14 ^{2) 8)}		K	-	All	All	✓	✓	✓	✓	✓	✓	-	-		
IM V19 ²⁾		L	-	All	All	✓	✓	✓	✓	✓	✓	-	-		
IM V18 without protective cover ²⁾		M	-	All	All	✓	✓	✓	✓	✓	✓	-	-		
IM V18 with protective cover ^{2) 4) 5) 6)}		M	H00	All except ②, ⑧ and in combination with order code F90		✓	✓	✓	✓	✓	✓	-	-		
IM B34 ³⁾		N	-	All except ③ and ⑨		✓	✓	✓	✓	✓	✓	-	-		
With special flange next larger			Acc. to EN 50347		FT130	FT130	FT165	FT165	FT215	-	-	-			
			Acc. to DIN 42948		C 160	C 160	C 200	C 200	C 250	-	-	-			
IM B14 ^{2) 8)}		K	P01	All	All	✓	✓	✓	✓	✓	-	-			
IM V19 ²⁾		L	P01	All	All	✓	✓	✓	✓	✓	-	-			
IM V18 without protective cover ²⁾		M	P01	All	All	✓	✓	✓	✓	✓	-	-			
IM V18 with protective cover ^{2) 4) 5) 6)}		M	P01+H00	All except ②, ⑧ and in combination with order code F90		✓	✓	✓	✓	✓	-	-			
IM B34 ³⁾		N	P01	All except ③ and ⑨		✓	✓	✓	✓	✓	-	-			

For legends and footnotes, see Page 2/65.

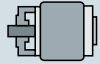
Supplements to article numbers and special versions SIMOTICS GP 1LE1/1PC1 Standard Motors

Types of construction · Aluminum series 1LE10, 1PC10

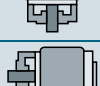
Types of construction	Type of construction letter 14th position of the Article No.	For types of construction with order code(s) Article No. with additional identification code -Z	Motor category									
			Motor version	Motor type (alum.)	Motor type – frame size							
					80	90	100	112	132	160	180	200
			IE2 High Efficiency	1LE1001	1LE1001 ①							
				1PC1001	1PC1001 ②							
			IE3 Premium Efficiency	1LE1041	1LE1041 APAC Line ③							
				1LE1003	1LE1003 ④							
			IE4 Super Premium Efficiency	1LE1043	1LE1043 APAC Line ⑤							
				1LE1004	1LE1004 ⑥							
			IE1 Standard Efficiency	1LE1002	1LE1002 ⑦							
				1PC1002	1PC1002 ⑧							
			NEMA Energy Efficient	1LE1021	1LE1021 Eagle Line ⑨							
			NEMA Premium Efficient	1LE1023	1LE1023 Eagle Line ⑩							
Pole-changing	1LE1011	1LE1011 ⑪										
	1LE1012	1LE1012 ⑫										
			Motor version	Motor type	Frame size							
					80	90	100	112	132	160	180	200
With special flange next smaller		Acc. to EN 50347 Acc. to DIN 42948			–	–	FT115 C 140	FT115 C 140	FT130 C 160	FT165 C 200	–	–
IM B14 2) 8)		K	P02	All except ⑥	–	–	O. R.	O. R.	O. R.	O. R.	–	–
IM V19 2)		L	P02	All except ⑥	–	–	O. R.	O. R.	O. R.	O. R.	–	–
IM V18 without protective cover 2)		M	P02	All except ⑥	–	–	O. R.	O. R.	O. R.	O. R.	–	–
IM V18 with protective cover 2) 4) 5) 6)		M	P02+H00	All except ②, ⑥ and ⑧ and in combination with order code F90	–	–	O. R.	O. R.	O. R.	O. R.	–	–
IM B34 3)		N	P02	All except ③, ⑥ and ⑨	–	–	O. R.	O. R.	O. R.	O. R.	–	–

- Standard version
- ✓ With additional charge
- Not possible
- O. R. Possible on request

- 1) The types of construction IM B6/7/8, IM V6 and IM V5 with/without protective cover are also possible as long as no condensation drainage holes (order code **H03**) and no stamping of these types of construction on the rating plate are required. As standard the type of construction IM B3 is then stamped on the rating plate. With type of construction IM V5 with protective cover, the protective cover has to be additionally ordered with order code **H00**. The protective cover is not stamped on the rating plate.
- 2) The type of construction is stamped on the rating plate. When ordering with condensation drainage holes (order code **H03**), if mounted in a different position, the position must be specified to ensure that the condensation drainage holes are positioned correctly.
- 3) For North America export version Eagle Line 1LE1021 NEMA Energy Efficient, types of construction with feet are not possible for 2-pole, 4-pole and 6-pole motors ≤ 200 hp in accordance with NEMA MG1 Table 12-11.
- 4) The "Standard cylindrical shaft extension" option (order code **L05**) is not possible.
- 5) In combination with an encoder it is not necessary to order the protective cover (order code **H00**), as this is delivered as a protection for the encoder as standard. In this case the protective cover is standard version (without additional charge).
- 6) Not possible for 1PC1 naturally cooled motors and 1LE1 forced-air cooled motors with order code **F90** without external fan and fan cover.
- 7) The types of construction IM V3 and IM V1 with/without protective cover are also possible as long as no condensation drainage holes (order code **H03**) and no stamping of these types of construction on the rating plate are required. As standard the type of construction IM B5 is then stamped on the rating plate. With type of construction IM V1 with protective cover, the protective cover has to be additionally ordered with order code **H00**. The protective cover is not stamped on the rating plate.
- 8) The types of construction IM V19 and IM V18 with/without protective cover are also possible as long as no condensation drainage holes (order code **H03**) and no stamping of these types of construction on the rating plate are required. As standard the type of construction IM B14 is then stamped on the rating plate. With type of construction IM V18 with protective cover, the protective cover has to be additionally ordered with order code **H00**. The protective cover is not stamped on the rating plate.



Supplements to article numbers and special versions

SIMOTICS GP 1LE1/1PC1 Standard Motors

Motor protection · Aluminum series 1LE10, 1PC10

Selection and ordering data

Motor protection	Motor protection letter 15th position in Article No.	Additional identification code with order code and plain text if required	Motor category									
			Motor version	Motor type (alum.)	Motor type – frame size							
					80	90	100	112	132	160	180	200
			IE2 High Efficiency	1LE1001	1LE1001							
				1PC1001	1PC1001							
				1LE1041	1LE1041 APAC Line							
			IE3 Premium Efficiency	1LE1003	1LE1003							
				1LE1043	1LE1043 APAC Line							
			IE4 Super Premium Efficiency	1LE1004	1LE1004							
			IE1 Standard Efficiency	1LE1002	1LE1002							
				1PC1002	1PC1002							
			NEMA Energy Efficient	1LE1021	1LE1021 Eagle Line							
			NEMA Premium Efficient	1LE1023	1LE1023 Eagle Line							
Pole-changing	1LE1011	1LE1011										
	1LE1012	1LE1012										
1LE10 ■ . 1PC10 ■ .			Motor version	Motor type	Frame size							
					80	90	100	112	132	160	180	200
Motor protection (winding protection)												
Without motor protection ¹⁾	A	–	All	All	□	□	□	□	□	□	□	□
Motor protection with PTC thermistors with 1 or 3 embedded temperature sensors for tripping ²⁾	B	–	All	All	✓	✓	✓	✓	✓	✓	✓	✓
Motor protection by PTC thermistors with 2 or 6 embedded temperature sensors for alarm and tripping ²⁾	C	–	All	All	✓	✓	✓	✓	✓	✓	✓	✓
Motor temperature detection with embedded temperature sensor KTY 84-130 ²⁾	F	–	All	All	✓	✓	✓	✓	✓	✓	✓	✓
Motor temperature detection with embedded temperature sensor 2 × KTY 84-130 ²⁾	G	–	All	All	✓	✓	✓	✓	✓	✓	✓	✓
Installation of 3 Pt100 resistance thermometers ²⁾	H	–	All	All	–	–	✓	✓	✓	✓	✓	✓
NTC thermistors for tripping	Z	Q2A	All	All	–	–	✓	✓	✓	✓	–	–
Temperature detectors for tripping ²⁾	Z	Q3A	All	All	✓	✓	✓	✓	✓	✓	✓	✓

□ Standard version
 ✓ With additional charge
 – Not possible

¹⁾ Frame sizes 80 and 90 with voltage code 02 can only be supplied without motor protection (motor protection code A).

²⁾ Evaluation with appropriate tripping unit (see Catalog IC 10) is recommended. For pole-changing motors, double the number of temperature sensors or temperature detectors is required. This also results in a double additional charge.

Supplements to article numbers and special versions

SIMOTICS GP 1LE1/1PC1 Standard Motors

Terminal box position · Aluminum series 1LE10, 1PC10

Selection and ordering data

Terminal box position	Terminal box position code 16th position of the Article No.	Additional identification code with order code and plain text if required	Motor category									
			Motor version	Motor type (alum.)	Motor type – frame size							
					80	90	100	112	132	160	180	200
			IE2 High Efficiency	1LE1001	1LE1001							
				1PC1001	1PC1001							
				1LE1041	1LE1041 APAC Line							
			IE3 Premium Efficiency	1LE1003	1LE1003							
				1LE1043	1LE1043 APAC Line							
			IE4 Super Premium Efficiency	1LE1004	1LE1004							
			IE1 Standard Efficiency	1LE1002	1LE1002							
				1PC1002	1PC1002							
			NEMA Energy Efficient	1LE1021	1LE1021 Eagle Line							
			NEMA Premium Efficient	1LE1023	1LE1023 Eagle Line							
Pole-changing	1LE1011	1LE1011										
	1LE1012	1LE1012										
			Motor version	Motor type	Frame size							
					80	90	100	112	132	160	180	200
1LE10												
1PC10		Order code										
Terminal box position												
Terminal box top ¹⁾	4	–	All	All	☐	☐	☐	☐	☐	☐	☐	☐
Terminal box on RHS ²⁾	5	–	All	All	✓	✓	✓	✓	✓	✓	✓	✓
Terminal box on LHS ²⁾	6	–	All	All	✓	✓	✓	✓	✓	✓	✓	✓
Terminal box at bottom ^{2) 3)}	7	–	All	All	–	–	✓	✓	✓	✓	–	–
☐	Standard version											
✓	With additional charge											
–	Not possible											

¹⁾ For types of construction with feet up to and including frame size 160, cast feet are standard. Screwed-on feet are available with order code **H01**. Frame sizes 180 and 200 are fitted as standard with screwed-on feet.

²⁾ For types of construction with feet, screwed-on feet are standard.

³⁾ Not generally possible for motors with feet.

Supplements to article numbers and special versions

SIMOTICS GP 1LE1/1PC1 Standard Motors

Options · Aluminum series 1LE10, 1PC10

Selection and ordering data

Special versions	Additional identification code -Z with order code and plain text if required	Motor category											
		Motor version	Motor type (alum.)	Motor type – frame size									
				80	90	100	112	132	160	180	200		
		IE2 High Efficiency	1LE1001	1LE1001 ①									
			1PC1001			1PC1001 ②							
			1LE1041	1LE1041 APAC Line ③									
		IE3 Premium Efficiency	1LE1003	1LE1003 ④									
			1LE1043	1LE1043 APAC Line ⑤									
		IE4 Super Premium Efficiency	1LE1004			1LE1004 ⑥							
		IE1 Standard Efficiency	1LE1002			1LE1002 ⑦							
			1PC1002			1PC1002 ⑧							
		NEMA Energy Efficient	1LE1021	1LE1021 Eagle Line ⑨									
		NEMA Premium Efficient	1LE1023	1LE1023 Eagle Line ⑩									
Pole-changing	1LE1011			1LE1011 ⑪									
	1LE1012			1LE1012 ⑫									
1LE10 -Z 1PC10 -Z		Motor version	Motor type	Frame size									
				80	90	100	112	132	160	180	200		
Motor connection and terminal box													
External grounding	H04	All	All	✓	✓	✓	✓	✓	✓	✓	✓		
Terminal box on NDE ³⁾	H08	All	All	✓	✓	✓	✓	✓	✓	✓	✓		
Rotation of the terminal box through 90°, entry from DE ¹⁾	R10	All	All	○	○	○	○	○	○	✓	✓		
Rotation of the terminal box through 90°, entry from NDE	R11	All	All	○	○	○	○	○	○	✓	✓		
Rotation of the terminal box through 180°	R12	All	All	○	○	○	○	○	○	✓	✓		
One metal cable gland	R15	All	All	✓	✓	✓	✓	✓	✓	✓	✓		
Cable gland, maximum configuration	R18	All	All	–	–	–	–	–	–	✓	✓		
3 cables protruding, 0.5 m long ⁴⁾⁵⁾	R20	All except ⑪ and ⑫		✓	✓	✓	✓	✓	✓	–	–		
3 cables protruding, 1.5 m long ⁴⁾⁵⁾	R21	All except ⑪ and ⑫		✓	✓	✓	✓	✓	✓	O. R.	O. R.		
6 cables protruding, 0.5 m long ⁴⁾	R22	All	All	✓	✓	✓	✓	✓	✓	–	–		
6 cables protruding, 1.5 m long ⁴⁾	R23	All	All	✓	✓	✓	✓	✓	✓	O. R.	O. R.		
6 cables protruding, 3 m long ⁴⁾	R24	All	All	✓	✓	✓	✓	✓	✓	O. R.	O. R.		
Reduction piece for M cable gland in accordance with British Standard, both cable entries mounted ²⁾	R30	All	All	–	–	✓	✓	✓	✓	–	–		
Larger terminal box	R50	All, standard version for Eagle Line ⑨ and ⑩ < Size 100		✓	✓	✓	✓	✓	✓	✓	✓		
Auxiliary terminal box, aluminum	R60 <i>New!</i>	All	All	–	–	–	–	–	–	✓	✓		
Motor connector Han-Drive 10e for 230 VΔ/400 VY ³⁰⁾	R70	All	All	✓	✓	✓	✓	✓	–	–	–		
Motor connector Han-Drive 10e EMC for 230 VΔ/400 VY ³⁰⁾	R71	All	All	✓	✓	✓	✓	✓	–	–	–		
Small motor connector CQ12 with EMC	R72	All	All	✓	✓	–	–	–	–	–	–		
Small motor connector CQ12 without EMC	R73	All	All	✓	✓	–	–	–	–	–	–		
6-piece terminal board	R76 <i>New!</i>	All, only possible for 2 and 4-pole motors, not possible for ⑥		○	○	–	–	–	–	–	–		
Windings and insulation													
Temperature class 155 (F), utilized acc. to 155 (F), with service factor (SF)	N01	All	All	–	–	✓	✓	✓	✓	✓	✓		
Temperature class 155 (F), utilized acc. to 155 (F), with increased output	N02	All	All	–	–	✓	✓	✓	✓	✓	✓		
Temperature class 155 (F), utilized acc. to 155 (F), with increased coolant temperature	N03	All	All	✓	✓	✓	✓	✓	✓	✓	✓		
Temperature class 155 (F), utilized acc. to 130 (B), coolant temperature 45 °C, derating approx. 4 %	N05	All	All	✓	✓	✓	✓	✓	✓	✓	✓		
Temperature class 155 (F), utilized acc. to 130 (B), coolant temperature 50 °C, derating approx. 8 %	N06	All	All	✓	✓	✓	✓	✓	✓	✓	✓		
Temperature class 155 (F), utilized acc. to 130 (B), coolant temperature 55 °C, derating approx. 13 %	N07	All	All	✓	✓	✓	✓	✓	✓	✓	✓		

For legends and footnotes, see Page 2/79.

Supplements to article numbers and special versions SIMOTICS GP 1LE1/1PC1 Standard Motors

Options · Aluminum series 1LE10, 1PC10

Special versions	Additional identification code -Z with order code and plain text if required	Motor category																
		Motor version	Motor type (alum.)	Motor type – frame size							80	90	100	112	132	160	180	200
		IE2 High Efficiency	1LE1001	1LE1001 ①														
			1PC1001								1PC1001 ②							
		IE3 Premium Efficiency	1LE1041	1LE1041 APAC Line ③														
			1LE1003	1LE1003 ④														
		IE4 Super Premium Efficiency	1LE1004								1LE1004 ⑥							
			1LE1002								1LE1002 ⑦							
		IE1 Standard Efficiency	1PC1002								1PC1002 ⑧							
			NEMA Energy Efficient	1LE1021	1LE1021 Eagle Line ⑨													
		NEMA Premium Efficient	1LE1023	1LE1023 Eagle Line ⑩														
		Pole-changing	1LE1011								1LE1011 ⑪							
1LE1012								1LE1012 ⑫										
1LE10 -Z 1PC10 -Z	Order code	Motor version	Motor type	Frame size							80	90	100	112	132	160	180	200
Windings and insulation (continued)																		
Temperature class 155 (F), utilized acc. to 130 (B), coolant temperature 60 °C, derating approx. 18 %	N08	All	All	✓	✓	✓	✓	✓	✓	✓	✓	✓	✓	✓	✓	✓	✓	✓
Temperature class H ³¹⁾	N10	All except ③, ⑤, ⑥, ⑧ and ⑩		✓	✓	–	–	–	–	–	–	–	–	–	–	–	–	–
Temperature class 180 (H) at rated output and max. CT 60 °C ^{6) 31)}	N11	All except ⑥		✓	✓	✓	✓	✓	✓	✓	✓	✓	✓	✓	✓	✓	✓	✓
Increased air humidity/temperature with 30 to 60 g water per m ³ of air	N20	All	All	✓	✓	✓	✓	✓	✓	✓	✓	✓	✓	✓	✓	✓	✓	✓
Increased air humidity/temperature with 60 to 100 g water per m ³ of air	N21	All	All	✓	✓	✓	✓	✓	✓	✓	✓	✓	✓	✓	✓	✓	✓	✓
Temperature class 155 (F), utilized acc. to 130 (B), with higher coolant temperature and/or installation altitude	Y50 • and specified output, CT ... °C or IA ... m above sea level	All	All	✓	✓	✓	✓	✓	✓	✓	✓	✓	✓	✓	✓	✓	✓	✓
Temperature class 155 (F), utilized according to 155 (F), other requirements	Y52 • and customer specifications	All	All	✓	✓	✓	✓	✓	✓	✓	✓	✓	✓	✓	✓	✓	✓	✓
Temperature class 180 (H), utilized according to 155 (F), other requirements	Y75 • <i>New!</i> and specified output, CT ... °C or IA ... m above sea level	All except ⑥		–	–	O.R.	O.R.	O.R.	O.R.	–	–	–	–	–	–	–	–	–
Colors and paint finish																		
Standard finish in RAL 7030 stone gray		All	All	□	□	□	□	□	□	□	□	□	□	□	□	□	□	□
Unpainted (only cast-iron parts primed)	S00	All	All	○	○	○	○	○	○	○	○	○	○	○	○	○	○	○
Unpainted, only primed	S01	All	All	✓	✓	✓	✓	✓	✓	✓	✓	✓	✓	✓	✓	✓	✓	✓
Special finish	S02 <i>New!</i>	All	All	✓	✓	✓	✓	✓	✓	✓	✓	✓	✓	✓	✓	✓	✓	✓
Special finish sea air resistant	S03	All	All	–	–	✓	✓	✓	✓	✓	✓	✓	✓	✓	✓	✓	✓	✓
Top coat polyurethane ³⁴⁾	S06 <i>New!</i>	All	All	✓	✓	✓	✓	✓	✓	✓	✓	✓	✓	✓	✓	✓	✓	✓
Finish in other standard RAL colors: RAL 1002, 1013, 1015, 1019, 2003, 2004, 3000, 3007, 5007, 5009, 5010, 5012, 5015, 5017, 5018, 5019, 6011, 6019, 6021, 7000, 7001, 7004, 7011, 7016, 7022, 7031, 7032, 7033, 7035, 9001, 9002, 9005 (see Catalog Section 1 "Introduction")	Y53 • <i>New!</i> and finish RAL	All	All	–	–	–	–	–	–	–	–	–	–	–	–	–	–	–
Finish in special RAL colors: For RAL colors, see "Special finish in special RAL colors" (see Catalog Section 1 "Introduction")	Y56 • <i>New!</i> and finish RAL	All	All	✓	✓	✓	✓	✓	✓	✓	✓	✓	✓	✓	✓	✓	✓	✓



Supplements to article numbers and special versions

SIMOTICS GP 1LE1/1PC1 Standard Motors

Options · Aluminum series 1LE10, 1PC10

Special versions	Additional identification code -Z with order code and plain text if required	Motor category																
		Motor version	Motor type (alum.)	Motor type – frame size							180	200						
				80	90	100	112	132	160									
		IE2 High Efficiency	1LE1001	1LE1001 ①														
			1PC1001	1PC1001 ②														
			1LE1041	1LE1041 APAC Line ③														
		IE3 Premium Efficiency	1LE1003	1LE1003 ④														
			1LE1043	1LE1043 APAC Line ⑤														
		IE4 Super Premium Efficiency	1LE1004		1LE1004 ⑥													
		IE1 Standard Efficiency	1LE1002		1LE1002 ⑦													
			1PC1002		1PC1002 ⑧													
		NEMA Energy Efficient	1LE1021	1LE1021 Eagle Line ⑨														
		NEMA Premium Efficient	1LE1023	1LE1023 Eagle Line ⑩														
Pole-changing	1LE1011		1LE1011 ⑪															
	1LE1012		1LE1012 ⑫															
1LE10 -Z 1PC10 -Z	Order code	Motor version	Motor type	Frame size							80	90	100	112	132	160	180	200
Modular technology – Basic versions 7)																		
Mounting of holding brake (standard assignment) 8) 28)	F01	All except ②, ⑧ and in combination with order code F90		✓	✓	✓	✓	✓	✓	✓	✓	✓	✓	✓	✓	✓	✓	
Mounting of brake for higher switching frequency (operating brake)	F02	All	All	O. R.	O. R.	O. R.	O. R.	O. R.	O. R.	O. R.	O. R.	O. R.	O. R.	O. R.	O. R.	O. R.	O. R.	
Mounting of separately driven fan 29)	F70	All except ②, ⑧ and in combination with order code F90		✓	✓	✓	✓	✓	✓	✓	✓	✓	✓	✓	✓	✓	✓	
Mounting of 1XP8012-10 (HTL) rotary pulse encoder 9) 10)	G01	All except ②, ⑧ and in combination with order code F90		✓	✓	✓	✓	✓	✓	✓	✓	✓	✓	✓	✓	✓	✓	
Mounting of 1XP8012-20 (TTL) rotary pulse encoder 9) 10)	G02	All except ②, ⑧ and in combination with order code F90		✓	✓	✓	✓	✓	✓	✓	✓	✓	✓	✓	✓	✓	✓	
Modular technology – Additional versions																		
Brake supply voltage 24 V DC	F10	All except ②, ⑧ and in combination with order code F90		✓	✓	✓	✓	✓	✓	✓	✓	✓	✓	✓	✓	✓	✓	
Brake supply voltage 230 V AC, 50/60 Hz	F11	All except ②, ⑧ and in combination with order code F90		✓	✓	○	○	○	○	○	○	○	○	○	○	○	○	
Brake supply voltage 400 V AC, 50/60 Hz	F12	All except ②, ⑧ and in combination with order code F90		✓	✓	✓	✓	✓	✓	✓	✓	✓	✓	✓	✓	✓	✓	
Mechanical manual brake release with lever (no locking)	F50	All except ②, ⑧ and in combination with order code F90		✓	✓	✓	✓	✓	✓	✓	✓	✓	✓	✓	✓	✓	✓	
Special technology 6)																		
Mounting of LL 861 900 220 rotary pulse encoder 9)	G04	All except ②, ⑧ and in combination with order code F90		–	–	✓	✓	✓	✓	✓	✓	✓	✓	✓	✓	✓	✓	
Mounting of HQG 9 D 1024 I rotary pulse encoder 9)	G05	All except ②, ⑧ and in combination with order code F90		–	–	✓	✓	✓	✓	✓	✓	✓	✓	✓	✓	✓	✓	
Mounting of HQG 10 D 1024 I rotary pulse encoder 9)	G06	All except ②, ⑧ and in combination with order code F90		–	–	✓	✓	✓	✓	✓	✓	✓	✓	✓	✓	✓	✓	
Mechanical design and degrees of protection																		
Low-noise version for 2-pole motors with clockwise direction of rotation	F77	All except ②, ⑧ and in combination with order code F90		–	–	–	–	✓	✓	✓	✓	✓	✓	✓	✓	✓	✓	
Low-noise version for 2-pole motors with counter-clockwise direction of rotation	F78	All except ②, ⑧ and in combination with order code F90		–	–	–	–	✓	✓	✓	✓	✓	✓	✓	✓	✓	✓	
Prepared for mountings, center hole only 10)	G40	All except ②, ⑧ and in combination with order code F90		✓	✓	✓	✓	✓	✓	✓	✓	✓	✓	□	□	□	□	
Prepared for mountings with D12 shaft 15)	G41	All except ②, ⑧ and in combination with order code F90		✓	✓	✓	✓	✓	✓	✓	✓	✓	✓	✓	✓	✓	✓	
Prepared for mountings with D16 shaft 15)	G42	All except ②, ⑧ and in combination with order code F90		O. R.	O. R.	✓	✓	✓	✓	✓	✓	✓	✓	✓	✓	✓	✓	
Protective cover for encoder (pre-assembled or supplied loose depending on frame size)	G43	All except ②, ⑧ and in combination with order code F90		✓	✓	✓	✓	✓	✓	✓	✓	✓	✓	✓	✓	✓	✓	
Protective cover 9) 11)	H00	All except ②, ⑧ and in combination with order code F90		✓	✓	✓	✓	✓	✓	✓	✓	✓	✓	✓	✓	✓	✓	
Screwed-on (instead of cast) feet	H01	All	All	✓	✓	✓	✓	✓	✓	✓	✓	✓	✓	□	□	□	□	
Vibration-proof version; vibration resistance to Class 3M4 according to IEC 60721-3-3	H02	All	All	–	–	✓	✓	✓	✓	✓	✓	✓	✓	✓	✓	✓	✓	
Condensation drainage holes 14)	H03	All	All	✓	✓	✓	✓	✓	✓	✓	✓	✓	✓	✓	✓	✓	✓	
Rust-resistant screws (externally)	H07	All	All	✓	✓	✓	✓	✓	✓	✓	✓	✓	✓	✓	✓	✓	✓	
Housing with screw mounting 32)	H10	Only possible for ① and ③ (frame sizes 80 and 90), ④, ⑤, ⑨ and ⑩		✓	✓	–	–	–	–	–	–	–	–	✓	✓	✓	✓	
IP65 degree of protection 13)	H20	All	All	✓	✓	✓	✓	✓	✓	✓	✓	✓	✓	✓	✓	✓	✓	
IP56 degree of protection 12)	H22	All	All	✓	✓	✓	✓	✓	✓	✓	✓	✓	✓	✓	✓	✓	✓	
Drive-end seal for flange-mounting motors, oil-tight to 0.1 bar 16)	H23	All	All	✓	✓	✓	✓	✓	✓	✓	✓	✓	✓	✓	✓	✓	✓	

For legends and footnotes, see Page 2/79.

Supplements to article numbers and special versions

SIMOTICS GP 1LE1/1PC1 Standard Motors

Options · Aluminum series 1LE10, 1PC10

Special versions	Additional identification code -Z with order code and plain text if required	Motor category																	
		Motor version	Motor type (alum.)	Motor type – frame size						80	90	100	112	132	160	180	200		
		IE2 High Efficiency	1LE1001	1LE1001 ①															
			1PC1001		1PC1001 ②														
			1LE1041	1LE1041 APAC Line ③															
		IE3 Premium Efficiency	1LE1003	1LE1003 ④															
			1LE1043	1LE1043 APAC Line ⑤															
		IE4 Super Premium Efficiency	1LE1004		1LE1004 ⑥														
		IE1 Standard Efficiency	1LE1002		1LE1002 ⑦														
			1PC1002		1PC1002 ⑧														
		NEMA Energy Efficient	1LE1021	1LE1021 Eagle Line ⑨															
		NEMA Premium Efficient	1LE1023	1LE1023 Eagle Line ⑩															
Pole-changing	1LE1011		1LE1011 ⑪																
	1LE1012		1LE1012 ⑫																
1LE10 -Z 1PC10 -Z		Motor version	Motor type	Frame size						80	90	100	112	132	160	180	200		
Coolant temperature and installation altitude																			
Coolant temperature -40 to +40 °C ^{16) 28)}	D03	All	All	✓	✓	✓	✓	✓	✓	✓	✓	✓	✓	✓	✓	✓	✓		
Coolant temperature -30 to +40 °C ^{16) 28)}	D04	All	All	✓	✓	✓	✓	✓	✓	✓	✓	✓	✓	✓	✓	✓	✓		
Designs in accordance with standards and specifications																			
VIK version	C02	Only possible for ① and ④		✓	✓	✓	✓	✓	✓	✓	✓	✓	✓	✓	✓	✓	✓		
Motor without CE marking for export outside EEA (see EU Directive 640/2009)	D22	Only possible for ①, ②, ⑦ and ⑧		–	–	○	○	○	○	○	○	○	○	○	○	○	○		
Electrical according to NEMA MG1-12 ¹⁸⁾	D30	All, standard version for ⑤, ⑨ and ⑩		✓	✓	✓	✓	✓	✓	✓	✓	✓	✓	✓	✓	✓	✓		
Version according to UL with "Recognition Mark" ¹⁹⁾	D31	All, standard version for ⑤, ⑨ and ⑩		✓	✓	✓	✓	✓	✓	✓	✓	✓	✓	✓	✓	✓	✓		
KEMCO Korea Energy Efficiency Label	D33	Only possible for ⑤		○	○	○	○	○	○	○	○	○	○	○	○	○	○		
China Energy Efficiency Label	D34	Only possible for ①, ④, ⑤, ⑥, ⑨ and ⑩		–	–	○	○	○	○	○	○	○	○	○	○	○	○		
Canadian regulations (CSA) ^{37) 33)}	D40	All, standard version for ⑤, ⑨ and ⑩, not possible for ⑪ and ⑫		✓	✓	✓	✓	✓	✓	✓	✓	✓	✓	✓	Av. soon	Av. soon			
TR CU product safety certificate EAC for Eurasian customs union ³⁵⁾	D47 <i>New!</i>	All	All	✓	✓	✓	✓	✓	✓	✓	✓	✓	✓	✓	–	–			
Train-compatible version ³¹⁾	L82	All except ②, ⑥ and ⑧		✓	✓	✓	✓	✓	✓	✓	✓	✓	✓	✓	Av. soon	Av. soon			
Bearings and lubrication																			
Regreasing device with M10 x 1 grease nipple according to DIN 71412-A	L19 <i>New!</i>	All	All	–	–	–	–	–	–	–	–	–	–	–	–	–	–		
Located bearing DE	L20	All	All	✓	✓	✓	✓	✓	✓	✓	✓	✓	✓	✓	✓	✓	✓		
Located bearing NDE	L21	All	All	✓	✓	✓	✓	✓	✓	✓	✓	✓	✓	✓	✓	✓	✓		
Bearing design for increased cantilever forces ³⁶⁾	L22	All	All	–	–	✓	✓	✓	✓	✓	✓	✓	✓	✓	✓	✓	✓		
Regreasing device ²⁰⁾	L23	All	All	–	–	✓	✓	✓	✓	✓	✓	✓	✓	✓	✓	✓	✓		
Deep-groove bearings reinforced at both ends for DE and NDE, bearing size 63	L25	All	All	–	–	✓	✓	✓	✓	✓	✓	✓	✓	✓	✓	✓	✓		
Measuring nipple for SPM shock pulse measurement for bearing inspection ²⁰⁾	Q01	All	All	–	–	✓	✓	✓	✓	✓	✓	✓	✓	✓	✓	✓	✓		
Balance and vibration quantity																			
Vibration quantity level A		All	All	□	□	□	□	□	□	□	□	□	□	□	□	□	□		
Vibration quantity level B	L00	All	All	✓	✓	✓	✓	✓	✓	✓	✓	✓	✓	✓	✓	✓	✓		
Half-key balancing (standard)		All	All	□	□	□	□	□	□	□	□	□	□	□	□	□	□		
Balancing without key	L01	All	All	✓	✓	✓	✓	✓	✓	✓	✓	✓	✓	✓	✓	✓	✓		
Full-key balancing	L02	All	All	✓	✓	✓	✓	✓	✓	✓	✓	✓	✓	✓	✓	✓	✓		
Shaft and rotor																			
Shaft extension with standard dimensions, without feather keyway	L04	All	All	–	–	✓	✓	✓	✓	✓	✓	✓	✓	✓	✓	✓	✓		
Standard cylindrical shaft extension	L05	All except ②, ⑧ and in combination with order code F90		✓	✓	✓	✓	✓	✓	✓	✓	✓	✓	✓	✓	✓	✓		
Standard shaft made of stainless steel (e.g. 1.4021)	L06	All	All	✓	✓	✓	✓	✓	✓	✓	✓	✓	✓	✓	✓	✓	✓		
Concentricity of shaft extension in accordance with DIN 42955 Tolerance R	L07	All	All	✓	✓	✓	✓	✓	✓	✓	✓	✓	✓	✓	✓	✓	✓		
Concentricity of shaft extension, coaxiality and linear movement in accordance with DIN 42955 tolerance R for flange-mounting motors	L08	All	All	✓	✓	✓	✓	✓	✓	✓	✓	✓	✓	✓	✓	✓	✓		
Non-standard shaft extension, DE ²¹⁾	Y58 • and customer specifications	All	All	✓	✓	✓	✓	✓	✓	✓	✓	✓	✓	✓	✓	✓	✓		
Non-standard shaft extension, NDE ²¹⁾	Y59 • and customer specifications	All	All	✓	✓	✓	✓	✓	✓	✓	✓	✓	✓	✓	✓	✓	✓		

For legends and footnotes, see Page 2/79.

Supplements to article numbers and special versions

SIMOTICS GP 1LE1/1PC1 Standard Motors

Options · Aluminum series 1LE10, 1PC10

Special versions	Additional identification code -Z with order code and plain text if required	Motor category										
		Motor version	Motor type (alum.)	Motor type – frame size								
				80	90	100	112	132	160	180	200	
		IE2 High Efficiency	1LE1001 1PC1001	1LE1001 ①						1PC1001 ②		
			1LE1041	1LE1041 APAC Line ③								
		IE3 Premium Efficiency	1LE1003 1LE1043	1LE1003 ④						1LE1043 APAC Line ⑤		
		IE4 Super Premium Efficiency	1LE1004							1LE1004 ⑥		
		IE1 Standard Efficiency	1LE1002 1PC1002							1LE1002 ⑦		
										1PC1002 ⑧		
		NEMA Energy Efficient	1LE1021	1LE1021 Eagle Line ⑨								
		NEMA Premium Efficient	1LE1023	1LE1023 Eagle Line ⑩								
		Pole-changing	1LE1011 1LE1012							1LE1011 ⑪		
										1LE1012 ⑫		
	1LE10 -Z 1PC10 -Z	Order code	Motor version	Motor type	Frame size							
					80	90	100	112	132	160	180	200
Heating and ventilation												
Sheet metal fan cover	F74	All except ②, ⑧ and in combination with order code F90	✓	✓	✓	✓	✓	✓	✓	✓	✓	✓
Fan cover for textile industry ²²⁾	F75	All except ②, ⑧ and in combination with order code F90	✓	✓	✓	✓	✓	✓	✓	✓	✓	✓
Metal external fan ^{23) 29)}	F76	All except ②, ⑧ and in combination with order code F90	✓	✓	✓	✓	✓	✓	✓	✓	✓	✓
Without external fan and without fan cover	F90	All except ②, ⑧, ⑪ and ⑫	✓	✓	✓	✓	✓	✓	✓	✓	✓	✓
Anti-condensation heating for 230 V	Q02	All	✓	✓	✓	✓	✓	✓	✓	✓	✓	✓
Anti-condensation heating for 115 V	Q03	All	✓	✓	✓	✓	✓	✓	✓	✓	✓	✓
Rating plate and extra rating plates												
Extra rating plate for voltage tolerance ²⁴⁾	B07	All except ②, ⑧, ⑪, ⑫ and 8-pole motors	✓	✓	✓	✓	✓	✓	✓	✓	✓	✓
Second rating plate, loose ²⁵⁾	M10	All	✓	✓	✓	✓	✓	✓	✓	✓	✓	✓
Rating plate, stainless steel	M11	All	✓	✓	✓	✓	✓	✓	✓	✓	✓	✓
Extra rating plate or rating plate with deviating rating plate data	Y80 • and customer specifications	All	✓	✓	✓	✓	✓	✓	✓	✓	✓	✓
Extra rating plate with customer specifications	Y82 • and customer specifications	All	✓	✓	✓	✓	✓	✓	✓	✓	✓	✓
Additional information on rating plate and on package label (max. 20 characters)	Y84 • and customer specifications	All	✓	✓	✓	✓	✓	✓	✓	✓	✓	✓
Adhesive label, supplied loose (printed with: Article No., Serial No.: 2 lines of text)	Y85 • and customer specifications	All	–	–	✓	✓	✓	✓	✓	✓	✓	✓
Packaging, safety notes, documentation and test certificates												
Printed German/English Operating Instructions (Compact) enclosed ²⁷⁾		All	All	□	□	□	□	□	□	□	□	□
Printed German/English Operating Instructions (Compact) enclosed in each wire-lattice pallet ²⁷⁾	B01	All	All	○	○	○	○	○	○	○	○	○
Acceptance test certificate 3.1 according to EN 10204 ²⁸⁾	B02	All	All	✓	✓	✓	✓	✓	✓	✓	✓	✓
Printed German/English Operating Instructions enclosed	B04	All	All	✓	✓	✓	✓	✓	✓	✓	✓	✓
Document - Electrical data sheet	B60	All	All	✓	✓	✓	✓	✓	✓	✓	✓	✓
Document - Order dimensional drawing	B61	All	All	✓	✓	✓	✓	✓	✓	✓	✓	✓
Type test with heat run for horizontal motors, with acceptance	B83	All	All	✓	✓	✓	✓	✓	✓	✓	✓	✓
Wire-lattice pallet packaging	B99	All	All	○	○	○	○	○	○	○	○	○
Connected in star for dispatch	M01	All	All	–	–	✓	✓	✓	✓	✓	✓	✓
Connected in delta for dispatch	M02	All	All	–	–	✓	✓	✓	✓	✓	✓	✓

For legends and footnotes, see Page 2/79.

Supplements to article numbers and special versions

SIMOTICS GP 1LE1/1PC1 Standard Motors

Options · Aluminum series 1LE10, 1PC10

- Standard version
- Without additional charge
- This order code only determines the price of the version – Additional plain text is required
- ✓ With additional charge
- O. R. Possible on request
- Av. soon Available soon
- Not possible

- 1) With IM B5 flange, only possible in combination with **H08**.
- 2) Not possible in combination with order code **R15** "One metal cable gland".
- 3) With **H08**, feet dimensions C and CA differ from EN 50347! Further information is available in DT Configurator (see Appendix, "Tools and Configuring").
- 4) In combination with motor protection (15th position of the Article No.) or anti-condensation heating option, please inquire before ordering.
- 5) Not possible in combination with voltage code **22** or **34**.
- 6) Cannot be used for motors in UL version (order code **D31**). The grease lifetime specified in Catalog Section 1 "Introduction" refers to CT 40 °C. When the coolant temperature rises by 10 K, the grease service lifetime or relubrication interval is halved.
- 7) A second shaft extension is not possible. Please inquire for mounted brakes.
- 8) For order codes **F10**, **F11** and **F12**, the brake supply voltage must be specified or ordered.
- 9) All encoders are supplied with a protective cover as standard. The protective cover is omitted at the factory when a rotary pulse encoder is combined with a separately driven fan, because in this case the rotary pulse encoder is installed under the fan cover. In combination with a separately driven fan (order code **F70**) the 1XP8032-10 rotary pulse encoder is used instead of 1XP8012-10 or 1XP8032-20 is used instead of 1XP8012-20.
- 10) Motors that are prepared for additional mountings (order codes **G40**, **G41**, **G42**) are supplied without a protective cover as standard. If a protective cover is requested as a cover or mechanical protection for mountings provided by the customer, this can be ordered with order code **G43**. Not possible in combination with order code **L00** vibration quantity level B. In combination with a separately driven fan (order code **F70**) the 1XP8032-10 rotary pulse encoder is used instead of 1XP8012-10 or 1XP8032-20 is used instead of 1XP8012-20.
- 11) Order code **H00** provides mechanical protection for encoders.
- 12) Not possible in combination with brake 2LM8 – order code **F01**.
- 13) Not possible in combination with HOG 9 D 1024I rotary pulse encoder (order code **G05**) and/or brake 2LM8 (order code **F01**).
- 14) Supplied with the condensation drainage holes sealed at the drive end DE and non-drive end NDE (IP55, IP56, IP65). If the condensation drainage holes are required for motors of the IM B6, IM B7 or IM B8 type of construction (feet on side or top), the motors must be ordered in the respective type of construction and with order code **H03**, so that the condensation drainage holes will be placed in the correct position.
- 15) Motors that are prepared for additional mountings (order codes **G40**, **G41**, **G42**) are supplied without a protective cover as standard. If a protective cover is requested as a cover or mechanical protection for mountings provided by the customer, this can be ordered with order code **G43**. Not possible in combination with order code **L00** vibration quantity level B.
- 16) In connection with mountings, the respective technical specifications must be observed, please inquire before ordering.
- 17) CCC certification is required for
 - 2-pole motors ≤ 2.2 kW
 - 4-pole motors ≤ 1.1 kW
 - 6-pole motors ≤ 0.75 kW
 - 8-pole motors ≤ 0.55 kW
- 18) Possible up to 600 V max. The rated voltage is indicated on the rating plate without voltage range. Order codes **D30** and **D31** do not authorize importing into USA and Mexico. The North America export versions Eagle Line 1LE1021 NEMA Energy Efficient and 1LE1023 NEMA Premium Efficient are available for this purpose.
- 19) In connection with mountings, the respective technical specifications must be observed, please inquire before ordering.
- 20) Not possible when brake is mounted.
- 21) When motors are ordered that have a longer or shorter shaft extension than normal, the required position and length of the feather keyway must be specified in a sketch. It must be ensured that only feather keys in accordance with DIN 6885, Form A are permitted to be used. The feather keyway is positioned centrally on the shaft extension. The length is defined by the manufacturer in accordance with the appropriate standard. Not valid for: Conical shafts, non-standard threaded journals, non-standard shaft tolerances, friction welded journals, extremely "thin" shafts, special geometry dimensions (e.g. square journals), hollow shafts. Valid for non-standard shaft extensions DE or NDE. The feather keys are supplied in every case. For order codes **Y58**, **Y59** and **L05**:
 - Dimensions D and DA ≤ Inner diameter of roller bearing (see tables under "Dimensions")
 - Dimensions E and EA ≤ x length E (normal) of the shaft extension.
- 22) The special requirements of the textile industry regarding the sheet metal cover open up the possibility that a finger may be inserted between the cover and enclosure. The customer must implement appropriate measures to ensure that the installed system is "finger-safe".
- 23) Converter operation is permitted for 1LE1 motors with metal external fans. The metal external fan is not possible in combination with the low-noise version – order code **F77** or **F78**.
- 24) Can be ordered for 230 VΔ/400 VY or 400 VΔ/690 VY (voltage code "**22**" or "**34**"). Not possible in combination with order code **D34**.
- 25) As adhesive label for frame sizes 80 and 90.
- 26) The delivery time for the factory test certificate may differ from the delivery time for the motor and it will be dispatched by email.
- 27) The Operating Instructions (compact) are available in PDF format for all official EU languages at <http://support.automation.siemens.com/WWW/view/en/40761976>.
- 28) Not possible in combination with order code **N05**, **N06**, **N07**, **N08** and **N11**.
- 29) Order codes **F70** and **F76** cannot be combined.
- 30) When ordering with order code **R70** and **R71**, order code **R50** is included.
- 31) Not possible for 2-pole and 4-pole motors with increased output (11th position of Article No.: 6) in frame sizes 80 and 90.
- 32) Possible with frame sizes 180 and 200 with screw-mounted fan cover.
- 33) Frame sizes 180 and 200 are designed with metric entry thread.
- 34) Order code **S06** cannot be combined with order code **S00** and **S01**. It can be combined with **Y53** and **Y56** on request.
- 35) Please note the additional use of order code **D22** "Motor without CE marking for export outside EEA (see EU Directive 640/2009)".
- 36) A minimum cantilever force F_{min} of $0.5 \cdot F_{max}$ is required for NU bearings (cylindrical roller bearings) in contrast to bearings. Cylindrical roller bearings are not suitable for coupling output or for brief periods of no-load operation without cantilever force.
- 37) The rated voltage is indicated on the rating plate without voltage range. Order code **D40** does not authorize importing into Canada. The North America export versions Eagle Line 1LE1021 NEMA Energy Efficient and 1LE1023 NEMA Premium Efficient are available for this purpose.

Übersicht

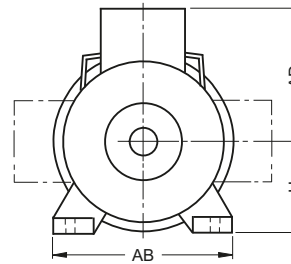
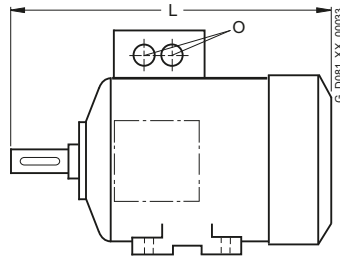

Bau- größe	Typ	Maß L	AD	H	AB	O
71 M	Graugussreihen, eigengekühlt					
	1LE1501, 1LE1521, 1LE1503-, 1LE1523- OCA2, OCB2, OCC2	240	148	71	132	2 × M25 × 1,5
	1LE1503-, 1LE1523- OCA3, OCB3, OCC3	280	148	71	132	2 × M25 × 1,5
80 M	Aluminiumreihe, eigengekühlt					
	1LE1001	292	121	80	150	1 × M25 × 1,5
	Aluminiumreihe, fremd- bzw. selbstgekühlt					
	1LE1001	253	121	80	150	1 × M25 × 1,5
	Graugussreihen, eigengekühlt					
	1LE1501, 1LE1521, 1LE1503-, 1LE1523- ODA2, ODB2, ODC2	292	158	80	150	2 × M25 × 1,5
1LE1503-, 1LE1523- ODA3, ODB3, ODC3	327	158	80	150	2 × M25 × 1,5	
90 S/ 90 L	Aluminiumreihe, eigengekühlt					
	1LE1001	347	126	90	165	1 × M25 × 1,5
	Aluminiumreihe, fremd- bzw. selbstgekühlt					
	1LE1001	295	126	90	165	1 × M25 × 1,5
	Graugussreihen, eigengekühlt					
	1LE1501, 1LE1521, 1LE1503-, 1LE1523- OEA0, OEB0, OEC0	347	163	90	165	2 × M25 × 1,5
1LE1503-, 1LE1523- OEA4, OEB4, OEC4	387	163	90	165	2 × M25 × 1,5	
100 L	Aluminiumreihen, eigengekühlt					
	1LE1001, 1LE1002, 1LE1011, 1LE1012, 1LE1021	396 ¹⁾	166	100	196	2 × M32 × 1,5
	Aluminiumreihen, eigengekühlt, mit erhöhter Leistung					
	1LE1001, 1LE1002	431 ¹⁾	166	100	196	2 × M32 × 1,5
	Aluminiumreihen, fremd- bzw. -selbstgekühlt					
	1LE1001, 1PC1001, 1LE1002, 1PC1002, 1LE1021	322	166	100	196	2 × M32 × 1,5
	Aluminiumreihen, eigengekühlt					
	1LE1003, 1LE1023	431	166	100	196	2 × M32 × 1,5
	Aluminiumreihe, fremdgekühlt					
	1LE1023	357	166	100	196	2 × M32 × 1,5
	Graugussreihen, eigengekühlt					
	1LE1501, 1LE1503, 1LE1521, 1LE1601, 1LE1603, 1LE1621	389	193	100	196	2 × M32 × 1,5
1LE1523, 1LE1623	425	193	100	196	2 × M32 × 1,5	

Bau- größe	Typ	Maß L	AD	H	AB	O
112 M	Aluminiumreihen, eigengekühlt					
	1LE1001, 1LE1002, 1LE1011, 1LE1012, 1LE1021	389 ¹⁾	177	112	226	2 × M32 × 1,5
	Aluminiumreihen, eigengekühlt, mit erhöhter Leistung					
	1LE1001, 1LE1002	414 ¹⁾	177	112	226	2 × M32 × 1,5
	Aluminiumreihen, fremd- bzw. selbstgekühlt					
	1LE1001, 1PC1001, 1LE1002, 1PC1002, 1LE1021	311	177	112	226	2 × M32 × 1,5
	Aluminiumreihen, eigengekühlt					
	1LE1003, 1LE1023	414	177	112	226	2 × M32 × 1,5
	Aluminiumreihe, fremdgekühlt					
	1LE1023	336	177	112	226	2 × M32 × 1,5
132 S/M	Graugussreihen, eigengekühlt					
	1LE1501, 1LE1503, 1LE1521, 1LE1601, 1LE1603, 1LE1621	382	195	112	226	2 × M32 × 1,5
	1LE1523, 1LE1623	409	195	112	226	2 × M32 × 1,5
	Aluminiumreihen, eigengekühlt					
	1LE1001, 1LE1002, 1LE1011, 1LE1012, 1LE1021	465 ¹⁾	202	132	256	2 × M32 × 1,5
	Aluminiumreihen, eigengekühlt, mit erhöhter Leistung					
1LE1001, 1LE1002	515 ¹⁾	202	132	256	2 × M32 × 1,5	
Aluminiumreihen, fremd- bzw. -selbstgekühlt						
1LE1001, 1PC1001, 1LE1002, 1PC1002, 1LE1021	381	202	132	256	2 × M32 × 1,5	
Aluminiumreihen, eigengekühlt						
1LE1003-, 1LE1023-						
1CA0, 1CC0, 1CC2	465	202	132	256	2 × M32 × 1,5	
1CA1, 1CB0, 1CB2, 1CC3	515	202	132	256	2 × M32 × 1,5	
Aluminiumreihe, fremdgekühlt						
1LE1023-						
1CA0, 1CC0, 1CC2	381	202	132	256	2 × M32 × 1,5	
1CA1, 1CB0, 1CB2, 1CC3	431	202	132	256	2 × M32 × 1,5	
Graugussreihen, eigengekühlt						
1LE1501, 1LE1503, 1LE1521, 1LE1601, 1LE1603, 1LE1621	457	215	132	256	2 × M32 × 1,5	
1LE1523-, 1LE1623-						
1CA0, 1CC0, 1CC2	458	215	132	256	2 × M32 × 1,5	
1CA1, 1CB0, 1CB2, 1CC3	508	215	132	256	2 × M32 × 1,5	

¹⁾ Die Länge ist bis zur Lüfterhaubenspitze angegeben.

²⁾ Nur für polumschaltbare Typen 1LE1011-1DP6 und 1LE1012-1DQ6 beträgt das Maß L 664 mm.

Maße

Standardmotoren SIMOTICS GP/SD 1LE1/1PC1

Hüllmaße

Übersicht (Fortsetzung)

Bau- größe	Typ	Maß L	AD	H	AB	O
160 M/L	Aluminiumreihen, eigengekühlt 1LE1001, 1LE1002, 1LE1011, 1LE1012, 1LE1021	604 ^{1) 2)}	237	160	300	2 × M40 × 1,5
	Aluminiumreihen, eigengekühlt, mit erhöhter Leistung 1LE1001, 1LE1002	664 ¹⁾	237	160	300	2 × M40 × 1,5
	Aluminiumreihen, fremd- bzw. selbstgekühlt 1LE1001, 1PC1001, 1LE1002, 1PC1002, 1LE1021	510	237	160	300	2 × M40 × 1,5
	Graugussreihen, eigengekühlt 1LE1501, 1LE1503, 1LE1521, 1LE1601, 1LE1603, 1LE1621	594	265	160	300	2 × M40 × 1,5
	Aluminiumreihen, eigengekühlt 1LE1003, 1LE1023	604	237	160	300	2 × M40 × 1,5
	Aluminiumreihe, fremdgekühlt 1LE1023	510	237	160	300	2 × M40 × 1,5
	Graugussreihen, eigengekühlt 1LE1523, 1LE1623	596	261	160	300	2 × M40 × 1,5
	Aluminiumreihen, eigengekühlt 1LE1003, 1LE1023	664	237	160	300	2 × M40 × 1,5
	Aluminiumreihe, fremdgekühlt 1LE1023	570	237	160	300	2 × M40 × 1,5
	Graugussreihen, eigengekühlt 1LE1523, 1LE1623	656	261	160	300	2 × M40 × 1,5
180 M	Aluminiumreihe, eigengekühlt 1LE1001					
	1EA2, 1EB2	668	286	180	339	2 × M40 × 1,5
	Graugussreihen, eigengekühlt 1LE15.1-, 1LE16.1- 1EA2, 1EB2	668	286	180	339	2 × M40 × 1,5
	1EA6	698				
	1LE15.3-, 1LE16.3- 1EB2	668	286	180	339	2 × M40 × 1,5
	1EA2	698				
	Aluminiumreihen, eigengekühlt 1LE1001					
1EB4, 1EC4, 1ED4	668	286	180	339	2 × M40 × 1,5	
1EA6, 1EB6, 1EC6, 1ED6	698					
Graugussreihen, eigengekühlt 1LE15.1-, 1LE16.1- 1EC4, 1EC6	668	286	180	339	2 × M40 × 1,5	
1EB6	698					
1LE15.3-, 1LE16.3- 1EC4	668	286	180	339	2 × M40 × 1,5	
1EB4	698					
200 L	Aluminiumreihen, eigengekühlt 1LE1001					
	2AA4, 2AA5, 2AB5, 2AC4, 2AC5, 2AD5	721	315	200	378	2 × M50 × 1,5
	2AA6, 2AB6, 2AC6, 2AD6	746				
	Graugussreihen, eigengekühlt 1LE15.1-, 1LE16.1- 1EB6	698				
	1LE15.3-, 1LE16.3- 1EC4	668	286	180	339	2 × M40 × 1,5
	1EB4	698				
	Aluminiumreihen, eigengekühlt 1LE1001					
	2AA4, 2AA5, 2AB5, 2AC4, 2AC5	721	315	200	378	2 × M50 × 1,5
	2AA6	746				
	1LE15.3-, 1LE16.3- 2AA4, 2AC4	721	315	200	378	2 × M50 × 1,5
2AA5, 2AB5, 2AC5	746					
225 S	Graugussreihen, eigengekühlt 1LE15.1-, 1LE16.1- 2BB0, 2BD0	788	338	225	436	2 × M50 × 1,5
	1LE15.3-, 1LE16.3- 2BB0	788	338	225	436	2 × M50 × 1,5
	Graugussreihen, eigengekühlt 1LE15.1-, 1LE16.1- 2BA2, 2BA6	818	338	225	436	2 × M50 × 1,5
	2BB2, 2BB6, 2BC2, 2BC6, 2BD6	848				
	1LE15.3-, 1LE16.3- 2BA2	818	338	225	436	2 × M50 × 1,5
	2BB2, 2BC2	848				
	Graugussreihen, eigengekühlt 1LE15.1-, 1LE16.1- 2CA2, 2CA6, 2CB2, 2CC2, 2CC6, 2CD2, 2CD6	887	410	250	490	2 × M63 × 1,5
	2CB6	957				
	1LE15.3-, 1LE16.3- 2CA2, 2CB2, 2CC2	887	410	250	490	2 × M63 × 1,5
	Graugussreihen, eigengekühlt 1LE15.1-, 1LE16.1- 2DA2, 2DB0, 2DC0, 2DD0	960	433	280	540	2 × M63 × 1,5
1LE15.3, 1LE16.3 2DA0, 2DB0, 2DC0	960	433	280	540	2 × M63 × 1,5	
280 M	Graugussreihen, eigengekühlt 1LE15.1-, 1LE16.1- 2DA2, 2DB2, 2DC2, 2DC6, 2DD2, 2DD6	960	433	280	540	2 × M63 × 1,5
	2DA6, 2DB6	1070				
	1LE15.3-, 1LE16.3- 2DC2	960	433	280	540	2 × M63 × 1,5
	2DA2, 2DB2	1070				
	Graugussreihen, eigengekühlt 1LE15.1-, 1LE16.1- 3AA0	1052	515	315	610	2 × M63 × 1,5
	3AB0, 3AC0, 3AD0	1082				
	1LE15.3-, 1LE16.3- 3AA0	1052	515	315	610	2 × M63 × 1,5
3AB0, 3AC0	1082					
315 M	Graugussreihen, eigengekühlt 1LE15.1-, 1LE16.1- 3AC2, 3AD2	1082	515	315	610	2 × M63 × 1,5
	3AA2	1217				
	3AB2	1247				
	1LE15.3-, 1LE16.3- 3AA2	1217	515	315	610	2 × M63 × 1,5
	3AB2, 3AC2	1247				
	Graugussreihen, eigengekühlt 1LE15.1-, 1LE16.1- 3AA4	1217	515	315	610	2 × M63 × 1,5
	3AB4, 3AC4, 3AC5, 3AD4, 3AD5, 3AD6	1247				
3AA5, 3AA6	1372					
3AB5, 3AB6, 3AC6	1402					
1LE15.3-, 1LE16.3- 3AA4	1217	515	315	610	2 × M63 × 1,5	
3AB4, 3AC4	1247	515	315	610	2 × M63 × 1,5	
3AA5	1372					
3AB5, 3AC5, 3AC6	1402					

Übersicht

- Maßbezeichnungen nach DIN EN 50347 und IEC 60072.
- Passungen
Die in den Maßtabellen angegebenen Wellenenden (DIN 748) und Zentrierranddurchmesser (DIN EN 50347) werden mit folgenden Passungen ausgeführt:

Maßbezeichnung	ISO-Passung	DIN	ISO 286-2
D, DA	bis 30	j6	
	über 30 bis 50	k6	
	über 50	m6	
N	bis 250	j6	
	über 250	h6	
F, FA		h9	
K		H17	
S	Flansch (FF)	H17	

Bohrungen von Kupplungen und Riemenscheiben sollen eine ISO-Passung von mindestens H7 erhalten.

- Maßtoleranzen
Für folgende Maßbezeichnungen gelten die nachstehenden zulässigen Abweichungen:

Maßbezeichnung	Abmessung	zulässige Abweichung
H	bis 250	- 0,5
	über 250	- 1,0
E, EA		- 0,5

Passfedernuten und Passfedern (Maße GA, GC, F und FA) werden nach DIN 6885 Teil 1 hergestellt.

- Alle Maßangaben in mm.

Maßblattgenerator (innerhalb des Drive Technology Konfigurators)

Übersicht

Zu jedem konfigurierbaren Motor kann im Drive Technology Konfigurator (DT-Konfigurator) ein Maßbild erzeugt werden. Für alle anderen Motoren kann ein Maßbild angefordert werden.

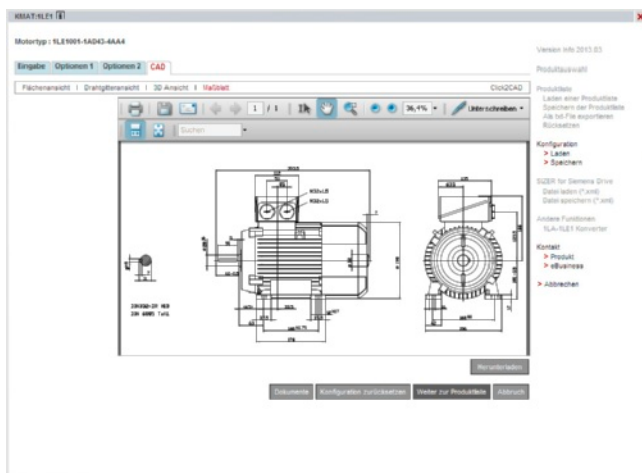

Sobald eine vollständige Artikel-Nr. mit oder ohne Kurzangaben eingegeben oder konfiguriert ist, besteht unter der Lasche Dokumentation die Möglichkeit ein Maßblatt aufzurufen. Diese Maßbilder können in verschiedenen Ansichten und Ausschnitten dargestellt und gedruckt werden. Die entsprechenden Maßblätter können als DXF-Format (Interchange-/Import-Format für CAD-Systeme) oder als Bitmap-Graphik exportiert, gespeichert und weiterverarbeitet werden.

Online-Zugang in der Siemens Industry Mall

Der DT-Konfigurator ist in der Siemens Industry Mall integriert und kann ohne Installation im Internet genutzt werden.

Deutsch: www.siemens.de/dt-konfigurator

Englisch: www.siemens.com/dt-configurator

Offline-Zugang im interaktiven Katalog CA01

Zusätzlich ist der DT-Konfigurator auch Bestandteil des interaktiven Kataloges CA01 auf DVD – der Offline-Version der Siemens Industry Mall. Der CA 01 kann über den jeweiligen Siemens Vertriebsansprechpartner angefordert oder im Internet bestellt werden: www.siemens.com/automation/CA01

Dimensions

SIMOTICS GP 1LE1 Standard Motors

Aluminum series 1LE100., 1LE1011, 1LE1012, 1LE1021, 1LE1041 · Self-ventilated, frame sizes 80 M to 200 L

Dimensional drawings

Type of construction IM B3

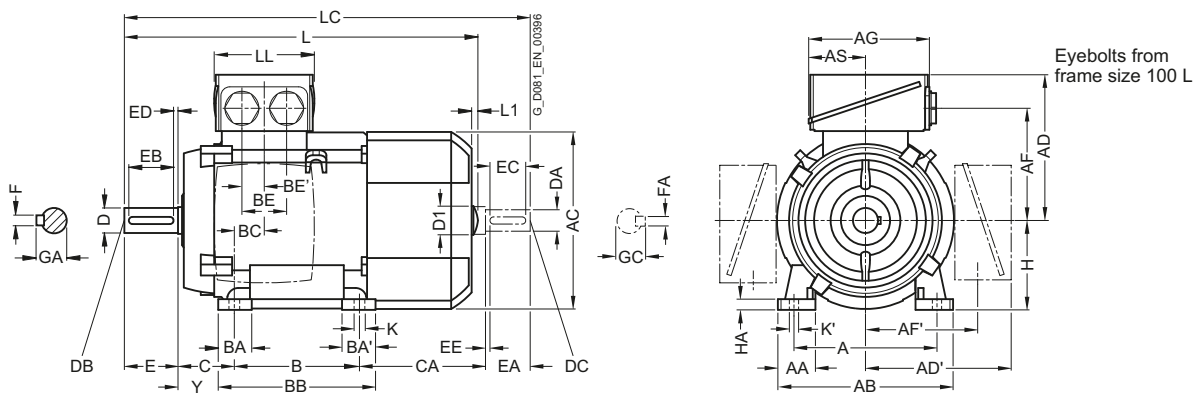

Types of construction IM B5 and IM V1

For flange dimensions, see Page 1/34 (Z = the number of retaining holes)

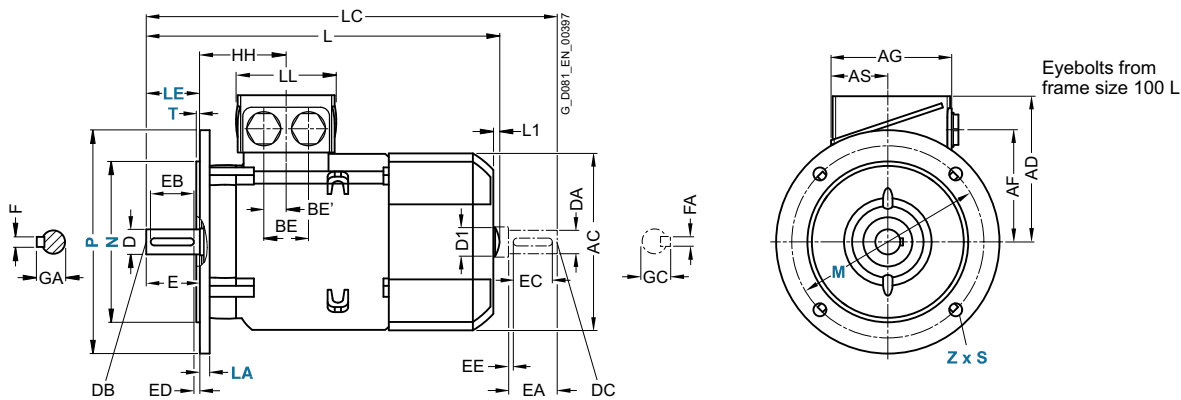

For motor	Dimension designation acc. to IEC																							
Frame size	Motor type	No. of poles	A	AA	AB	AC	AD	AD'	AF	AF'	AG	AS	B*	BA	BA'	BB	BC	BE	BE'	C	CA*	H	HA	Y
80 M	1LE1001	2, 4, 6	125	30.5	150	159	121	-	96.5	-	93	43	100	32	-	118	23	-	18 ¹⁾	50	-	80	8	41
90 S	1LE1041	2, 4, 6	140	30.5	165	178	126	-	101.5	-	93	43	100	33	-	143	22.5	-	18 ¹⁾	56	-	90	10	47
90 L		2, 4, 6	140	30.5	165	178	126	-	101.5	-	93	43	125	33	-	143	22.5	-	18 ¹⁾	56	-	90	10	47
100 L	All	2, 4, 6, 8	160	42	196	198	166	166	125.5	125.5	135	63.5	140	37.5	-	176	33.5	50	25	63	141	100	12	45
112 M	All	2, 4, 6, 8	190	46	226	222	177	177	136.5	136.5	135	63.5	140	35.4	-	176	26	50	25	70	129.7	112	12	52
132 S	All	2, 4, 6, 8	216	53	256	262	202	202	159.5	159.5	155	70.5	140	38	76	218	26.5	48	24	89	128.5	132	15	69
132 M	All	2, 4, 6, 8	216	53	256	262	202	202	159.5	159.5	155	70.5	178	38	76	218	26.5	48	24	89	128.5	132	15	69
160 M	All	2, 4, 6, 8	254	60	300	314	236.5	236.5	190	190	175	77.5	210	44	89	300	47	57	28.5	108	148	160	18	85
160 L	All	2, 4, 6, 8	254	60	300	314	236.5	236.5	190	190	175	77.5	254	44	89	300	47	57	28.5	108	148 ²⁾	160	18	85
180 M	All	2, 4, 6	279	65	339	356	259	259	212.5	212.5	175	77.5	241/ 279	80	100	328	30	57	28.5	121	-	180	20	95
180 L	All	2, 4, 6	279	65	339	356	259	259	212.5	212.5	175	77.5	241/ 279	80	100	328	30	57	28.5	121	-	180	20	95
200 L	All	2, 4, 6	318	70	378	396	296	296	238	238	225	102.5	305	90	100	355	45	75	37.5	133	-	200	25	108

* This dimension is assigned in EN 50347 to the frame size listed.

¹⁾ Connecting hole for terminal box is on the side at the rear of the terminal box.

²⁾ Only for pole-changing types 1LE1011-1DP6 and 1LE1012-1DQ6 the dimension CA* is 208 mm.

Dimensional drawings (continued)

Type of construction IM B35

For flange dimensions, see Page 1/34 (**Z** = the number of retaining holes)

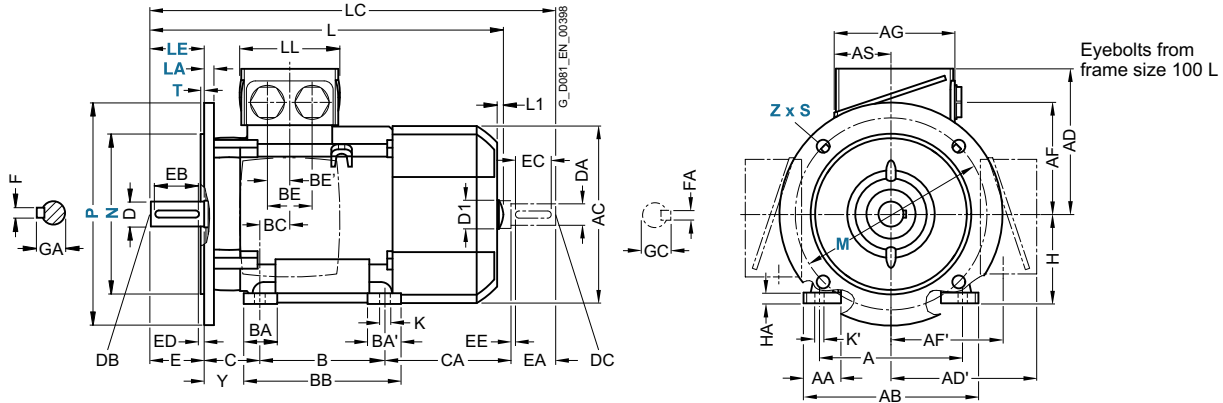

Type of construction IM B14

For flange dimensions, see Page 1/34 (**Z** = the number of retaining holes)

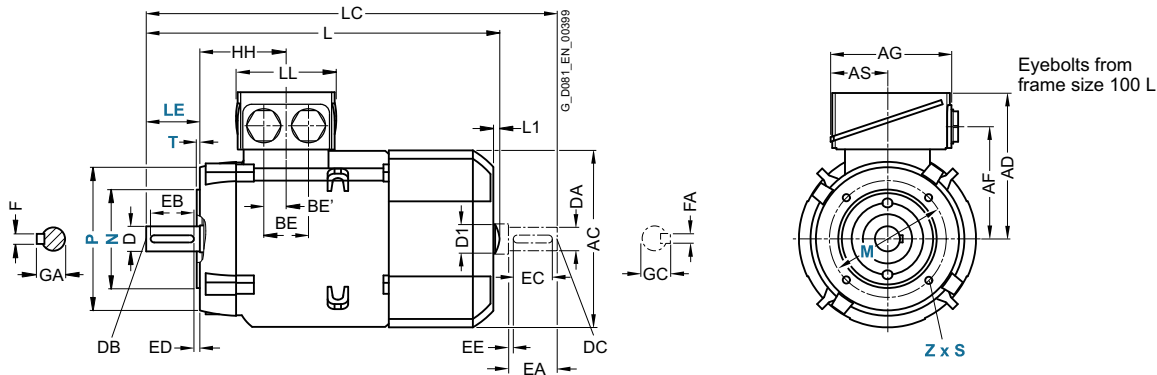

For motor Frame size	Motor type	No. of poles	Dimension designation acc. to IEC							DE shaft extension							NDE shaft extension							
			HH	K	K'	L	L1	D1	LC	LL	D	DB	E	EB	ED	F	GA	DA	DC	EA	EC	EE	FA	GC
80 M	1LE1001	2, 4, 6	73	9.5	13.5	292	-	-	-	79	19	M6	40	32	4	6	21.5	19	M6	40	32	4	6	21.5
90 S	1LE1041	2, 4, 6	78.5	10	14	347	-	-	-	79	24	M8	50	40	5	8	27	19	M6	40	32	4	6	21.5
90 L		2, 4, 6	78.5	10	14	347	-	-	-	79	24	M8	50	40	5	8	27	19	M6	40	32	4	6	21.5
100 L	All	2, 4, 6, 8	96.5	12	16	395.5 ¹⁾	7	32	454	112	28	M10	60	50	5	8	31	24	M8	50	40	5	8	27
112 M	All	2, 4, 6, 8	96	12	16	389 ¹⁾	7	32	450	112	28	M10	60	50	5	8	31	24	M8	50	40	5	8	27
132 S	All	2, 4, 6, 8	115.5	12	16	465 ¹⁾	8.5	39	535.5	130	38	M12	80	70	5	10	41	28	M10	60	50	5	8	31
132 M	All	2, 4, 6, 8	115.5	12	16	465 ¹⁾	8.5	39	535.5	130	38	M12	80	70	5	10	41	28	M10	60	50	5	8	31
160 M	All	2, 4, 6, 8	155	15	19	604 ¹⁾	10	45	730	145	42	M16	110	90	10	12	45	42	M16	110	90	10	12	45
160 L	All	2, 4, 6, 8	155	15	19	604 ¹⁾²⁾	10	45	730 ³⁾	145	42	M16	110	90	10	12	45	42	M16	110	90	10	12	45
180 M	All	2, 4, 6	151	14.5	19	699	-	-	814	145	48	M16	110	100	5	14	52	48	M16	110	100	5	14	52
180 L	All	2, 4, 6	151	14.5	19	699	-	-	814	145	48	M16	110	100	5	14	52	48	M16	110	100	5	14	52
200 L	All	2, 4, 6	178	18.5	25	746	-	-	860	185	55	M20	110	100	5	16	59	55	M20	110	100	5	16	59

¹⁾ The length is specified as far as the tip of the fan cover.

²⁾ Only for pole-changing types 1LE1011-1DP6 and 1LE1012-1DQ6 the dimension L is 664 mm.

³⁾ Only for pole-changing types 1LE1011-1DP6 and 1LE1012-1DQ6 the dimension LC is 790 mm.

Introduction

General technical specifications

Flange dimensions

Overview (continued)

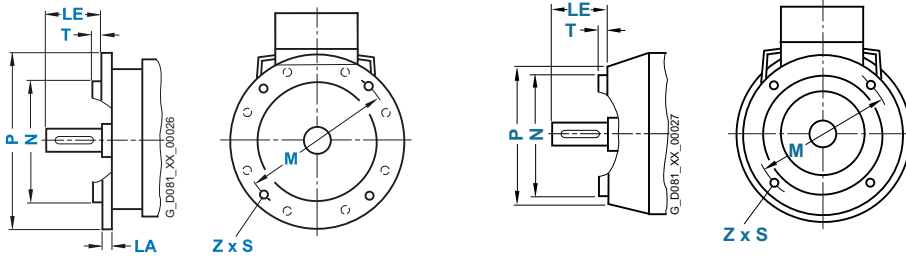

In EN 50347, the frame sizes are allocated flange FF with through holes and flange FT with tapped holes.

The designation of flange A and C according to DIN 42948 (invalid since September 2003) are also listed for information purposes. See the table below. (**Z** = the number of retaining holes)

Frame size	Type of construction	Flange type	Flange with through holes (FF/A) Flange with tapped holes (FT/C)		Dimension designation acc. to IEC							
			Acc. to EN 50347	Acc. to DIN 42948	LA	LE	M	N	P	S	T	Z
71 M	IM B5, IM B35, IM V1, IM V3	Standard flange	FF130	A 160	9	30	130	110	160	10	3.5	4
	IM B14, IM B34, IM V18, IM V19	Standard flange	FT85	C 105	–	30	85	70	105	M6	2.5	4
	IM B14, IM B34, IM V18, IM V19	Next larger standard flange – Order code P01	FT115	C 140	–	30	115	95	140	M8	3	4
80 M	IM B5, IM B35, IM V1, IM V3	Standard flange	FF165	A 200	10	40	165	130	200	12	3.5	4
	IM B14, IM B34, IM V18, IM V19	Standard flange	FT100	C 120	–	40	100	80	120	M6	3	4
	IM B14, IM B34, IM V18, IM V19	Next larger standard flange – Order code P01	FT130	C 160	–	40	130	110	160	M8	3.5	4
90 S/L	IM B5, IM B35, IM V1, IM V3	Standard flange	FF165	A 200	10	50	165	130	200	12	3.5	4
	IM B14, IM B34, IM V18, IM V19	Standard flange	FT115	C 140	–	50	115	95	140	M8	3	4
	IM B14, IM B34, IM V18, IM V19	Next larger standard flange – Order code P01	FT130	C 160	–	50	130	110	160	M8	3.5	4
100 L	IM B5, IM B35, IM V1, IM V3	Standard flange	FF215	A 250	11	60	215	180	250	14.5	4	4
	IM B5, IM B35, IM V1, IM V3	Next larger standard flange – Order code P01	FF265	A 300	12	60	265	230	300	14.5	4	4
	IM B5, IM B35, IM V1, IM V3	Next smaller standard flange – Order code P02	FF165	A 200	11	60	165	130	200	12	3.5	4
	IM B14, IM B34, IM V18, IM V19	Standard flange	FT130	C 160	–	60	130	110	160	M8	3.5	4
	IM B14, IM B34, IM V18, IM V19	Next larger standard flange – Order code P01	FT165	C 200	–	60	165	130	200	M10	3.5	4
112 M	IM B5, IM B35, IM V1, IM V3	Standard flange	FF215	A 250	11	60	215	180	250	14.5	4	4
	IM B5, IM B35, IM V1, IM V3	Next larger standard flange – Order code P01	FF265	A 300	12	60	265	230	300	14.5	4	4
	IM B5, IM B35, IM V1, IM V3	Next smaller standard flange – Order code P02	FF165	A 200	11	60	165	130	200	12	3.5	4
	IM B14, IM B34, IM V18, IM V19	Standard flange	FT130	C 160	–	60	130	110	160	M8	3.5	4
	IM B14, IM B34, IM V18, IM V19	Next larger standard flange – Order code P01	FT165	C 200	–	60	165	130	200	M10	3.5	4
132 S/M	IM B5, IM B35, IM V1, IM V3	Standard flange	FF265	A 300	12	80	265	230	300	14.5	4	4
	IM B5, IM B35, IM V1, IM V3	Next larger standard flange – Order code P01	FF300	A 350	13	80	300	250	350	18.5	5	4
	IM B5, IM B35, IM V1, IM V3	Next smaller standard flange – Order code P02	FF215	A 250	11	80	215	180	250	14.5	4	4
	IM B14, IM B34, IM V18, IM V19	Standard flange	FT165	C 200	–	80	165	130	200	M10	3.5	4
	IM B14, IM B34, IM V18, IM V19	Next larger standard flange – Order code P01	FT215	C 250	–	80	215	180	250	M12	4	4
160 M/L	IM B5, IM B35, IM V1, IM V3	Standard flange	FF300	A 350	13	110	300	250	350	18.5	5	4
	IM B5, IM B35, IM V1, IM V3	Next smaller standard flange – Order code P02	FF265	A 300	12	110	265	230	300	14.5	4	4
	IM B14, IM B34, IM V18, IM V19	Standard flange	FT215	C 250	–	110	215	180	250	M12	4	4
180 M/L	IM B5, IM B35, IM V1, IM V3	Standard flange	FF300	A 350	13	110	300	250	350	18.5	5	4
	IM B5, IM B35, IM V1, IM V3	Next smaller standard flange – Order code P02	FF 265	A 300	12	110	265	230	300	14.5	4	4
200 L	IM B5, IM B35, IM V1, IM V3	Standard flange	FF350	A 400	15	110	350	300	400	18.5	5	4
	IM B5, IM B35, IM V1, IM V3	Next smaller standard flange – Order code P02	FF300	A 350	13	110	300	250	350	18.5	5	4
225 S/M 2-pole 4- ... 8-pole	IM B5, IM B35, IM V1, IM V3	Standard flange	FF400	A 450	16	110	400	350	450	18.5	5	8
250 M	IM B5, IM B35, IM V1, IM V3	Standard flange	FF500	A 550	18	140	500	450	550	18.5	5	8
280 S/M	IM B5, IM B35, IM V1, IM V3	Standard flange	FF500	A 550	18	140	500	450	550	18.5	5	8
315 S/M/L 2-pole 4- ... 8-pole	IM B5, IM B35, IM V1, IM V3	Standard flange	FF600	A 660	22	140	600	550	660	24	6	8