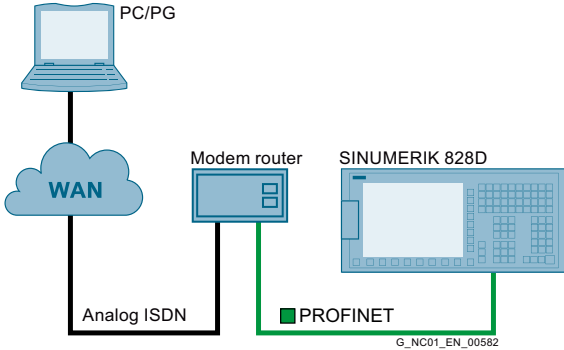
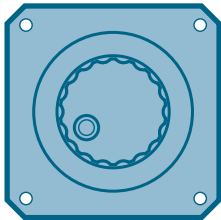

3D simulation, finished part Option P25 Article No.: 6FC5800-0AP25-0YB0	Required for enabling 3D view in part program simulation. 3D simulation can be viewed even in real-time simulation. Without this option, it is possible to see 2D simulation (with different views) in the system. If simultaneous recording option already exists in the system, then it is possible to have 3D view during the real-time simulation.																																
Access MyMachine /P2P Option P30 Article No.: 6FC5800-0AP30-0YB0	 <p>RCS Host remote diagnostics software for connection of a modem router to the X127 is solely necessary in case of connection via Modem router. It is possible to monitor and influence a control from a remote PC. The remote viewer gets the same display of SINUMERIK 828. A modem router is required for connecting SINUMERIK 828 to a viewer on a telephone line /internet Remote diagnosis has the following services:</p> <ul style="list-style-type: none"> • Direct access to SINUMERIK 828 • Data exchange (file transfer) 																																
Advanced technology functions Option P58 Article No.: 6FC5800-0AP58-0YB0	The following extended technologies are only available in SINUMERIK 828D BASIC. <ul style="list-style-type: none"> • Asymmetric grooves (only turning) • Drill and thread milling • Thread milling • Multi-edge milling • Engraving • Extended stock removal along contour with segmentation of blank (only turning) • Contour grooving and plunge turning (only turning) • Milling of contour pockets and spigots (with up to 12 islands) • Position pattern - hide position • Asymmetrically turn a shoulder • DIN thread undercut 																																
Axis/spindle, each additional Option Article No.: 6FC5800-0AC20-0YB0 (6FC5800-0AA00-0YB0 for V 2.x)	This option must be selected if the required number of interpolating axes/spindles is more than the basic quantity of axes/spindles. The basic quantity of axes offered by panel processing units/ SINUMERIK 828D family is given in the table below: <table border="1" data-bbox="443 1444 1417 1820"> <thead> <tr> <th></th> <th colspan="2">SINUMERIK 828D BASIC</th> <th>SINUMERIK 828D</th> </tr> <tr> <th></th> <th>PPU 24x.3</th> <th>PPU 26x.3</th> <th>PPU 28x.3</th> </tr> </thead> <tbody> <tr> <td>Basic quantity of axes</td> <td></td> <td></td> <td></td> </tr> <tr> <td>• Turning</td> <td>3</td> <td>3</td> <td>3</td> </tr> <tr> <td>• Milling</td> <td>4</td> <td>4</td> <td>4</td> </tr> <tr> <td>Max. possible quantity of axes/spindles</td> <td></td> <td></td> <td></td> </tr> <tr> <td>• Turning</td> <td>5</td> <td>6</td> <td>8</td> </tr> <tr> <td>• Milling</td> <td>5</td> <td>6</td> <td>6</td> </tr> </tbody> </table>		SINUMERIK 828D BASIC		SINUMERIK 828D		PPU 24x.3	PPU 26x.3	PPU 28x.3	Basic quantity of axes				• Turning	3	3	3	• Milling	4	4	4	Max. possible quantity of axes/spindles				• Turning	5	6	8	• Milling	5	6	6
	SINUMERIK 828D BASIC		SINUMERIK 828D																														
	PPU 24x.3	PPU 26x.3	PPU 28x.3																														
Basic quantity of axes																																	
• Turning	3	3	3																														
• Milling	4	4	4																														
Max. possible quantity of axes/spindles																																	
• Turning	5	6	8																														
• Milling	5	6	6																														

Glossary

Functions and terms

SINUMERIK 828

<p>Contour handwheel Option M08 Article No.: 6FC5800-0AM08-0YB0</p>	 <p>When the contour handwheel function is activated, the handwheel has a velocity-generating effect in AUTOMATIC and MDI modes on all programmed traversing movements of the path and synchronized axes. A feedrate specified via the CNC program becomes ineffective and a programmed velocity profile is no longer valid. The feedrate, in mm/min, results from the handwheel pulses as based on pulse weighting (machine data) and the active increment. The handwheel's direction of rotation determines the direction of travel:</p> <ul style="list-style-type: none"> • Clockwise: in the programmed direction of travel (even beyond block boundaries) • Counter-clockwise: against the programmed direction of travel (continuation beyond the start of the block is prevented).
<p>Evaluation of internal drive variables Option S53 Article No.: 6FC5800-0AS53-0YB0 (6FC5800-0AM41-0YB0 for V 2.x)</p>	<p>The following real-time drive variables can be accessed/evaluated in part program: \$AA_LOAD drive capacity utilization in Percentage (%) \$AA_POWER drive active power in Watts (W) \$AA_TORQUE drive torque set point in Newton meters (Nm) \$AA_CURR actual axis/spindle current in Ampere (A) These variables can be used along with synchronized options These variables can be also read through PLC interface, NC variables DB1200.DBxxxx. For the PLC purpose, evaluation of internal drives is standard. <u>Application examples :</u> Evaluation of these drive variables also permits machines and tools to be protected from overloading, as well as shorter machining times and an improved surface quality for the workpieces to be achieved. Evaluation of internal drive variables is a prerequisite for implementing adaptive control (AC). Adaptive control can be parameterized within the part program as follows:</p> <ul style="list-style-type: none"> • Additive influence: The programmed feed value is corrected by adding. • Multiplicative influence: The feed value is multiplied by a factor (override).
<p>Extended operator functions Option P16 Article No.: 6FC5800-0AP16-0YB0</p>	<ul style="list-style-type: none"> • Number of levels for skip blocks 10 (default value 2) • Teach-in function • Backup workpiece setup data • Display active synchronized actions • DRF offset • Overstoring • Extended block search (program/search pointer, level up/down, interrupt position) • Manual workpiece measurement: advanced strategies for part probing • Additional measuring version beyond standard scope (standard scope workpiece zero: Set edge, align edge, right-angled corner, 1 hole, and 1 circular spigot. Expansion of the measurement window via combo box) • Load/save MDI program

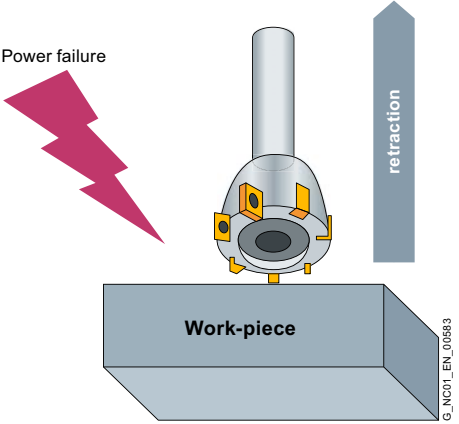
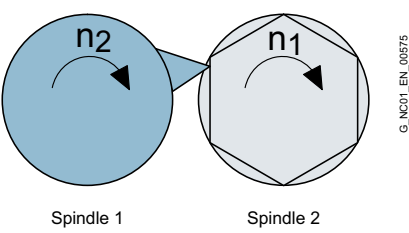
<p>Extended stop and retract ESR, drive-autonomous Option M60 Article No.: 6FC5800-0AM60-0YB0</p>	 <p>A safe position is assumed from the machining level without any collision between tool and workpiece.</p> <p>As well as the drive-autonomous stop and retract function, the CNC-controlled stop and retract functionality is also provided. To permit gentle interpolated retraction on the path or contour, the path interpolation can be processed further for a definable period following the triggering event. The retraction axes are subsequently traversed in synchronism to an absolute or incremental position as programmed.</p> <p>These functions are primarily used for gearing and grinding technologies.</p>
<p>Generic coupling Basic: CP-Basic Option M72 Article No.: 6FC5800-0AM72-0YB0</p>	 <ul style="list-style-type: none"> • Up to 4 × simple coupled motion and • Up to 1 × synchronous spindles/multi-edge turning or master value coupling/curve table interpolation or axial coupling in the machine coordinate system <p><u>Application example:</u> Multi-edge machining (polygonal turning)</p> <p>The synchronous spindle function provides the basis for multi-edge machining through specification of an integer gear ratio between leading spindle and following spindle. In the picture above, spindle 2 contains the job and spindle 1 has the cutting tool. Both the spindles are synchronized and run at a ratio (e.g.: 1:6), in order to get polygon shape on the job.</p>

Glossary

Functions and terms

SINUMERIK 828

Generic coupling Comfort: CP-Comfort

Option M73
Article No.:
6FC5800-0AM73-0YB0

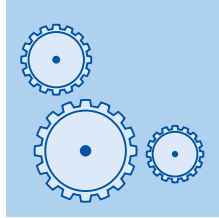

- Up to 4 × simple coupled motion and
- Up to 4 × synchronous spindle/multi-edge turning and/or master value coupling/curve table interpolation and/or axial coupling in the machine coordinate system

Also:

- 1 × electronic gear for up to 3 leading axes is possible (without curve table interpolation and without cascading)

Application example:

This option is suitable for the hobbing process. Gear hobbing machines are machines which have a rotating multiple-tooth cutting tool to produce teeth on helical gears, worm gears, cycloid gears, etc.

When two axes (e.g. tool axes) with different ratio must be coupled on to third axes (e.g. blank axes).

Generic coupling Static: CP-Static

Option M75
Article No.:
6FC5800-0AM75-0YB0

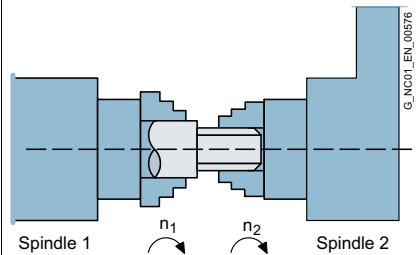

One simple synchronous spindle (with coupling ratio 1:1, no multi-edge machining)

Application example:

Reverse side machining in a double-spindle lathe with on-the-fly transfer of the work piece from the position-synchronous LS to the FS (or vice versa), without having to decelerate to standstill.

Inclined axis
Option M28
Article No.:
6FC5800-0AM28-0YB0

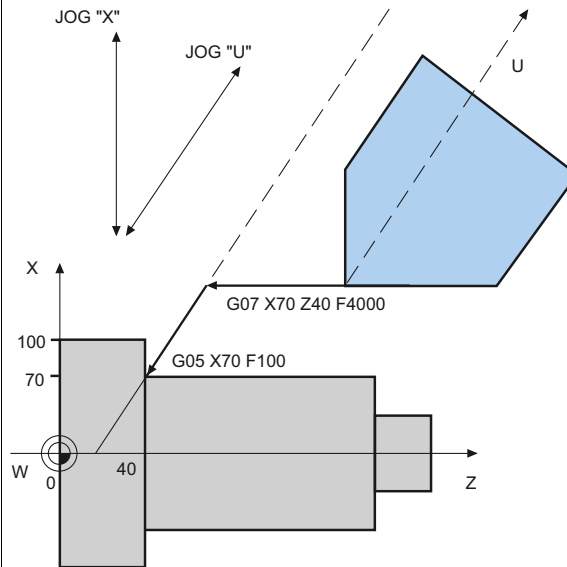

G_NC01_XX_00121

Oblique plunge-cut grinding: machine with non-Cartesian X axis (U)

The Inclined axis function is used for fixed-angle interpolation using an oblique infeed axis (used primarily in conjunction with cylindrical grinding machines). The axes are programmed and displayed in the Cartesian coordinate system. Tool offsets and work offsets are also entered in the Cartesian system and transformed to the real machine axes. For oblique plunge-cutting with G05, it is necessary to program the start position with G07.

Leadscrew error compensation, bidirectional:
Bidirectional threaded spindle error compensation
Option M54
Article No.:
6FC5800-0AM54-0YB0

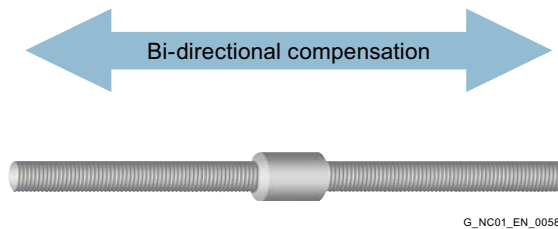

G_NC01_EN_00585

Bidirectional compensation is an expansion to the leadscrew error compensation function (LEC) or the measuring system error compensation function (MSEC). By contrast to LEC and MSEC, bidirectional compensation works in both directions. The option supports price sensitive front-face and peripheral side machining applications on lathes without a mechanical Y axis.

Glossary

Functions and terms

SINUMERIK 828

Machining step programming
ShopTurn/ShopMill
 Option P17
 Article No.:
 6FC5800-OAP17-OYB0

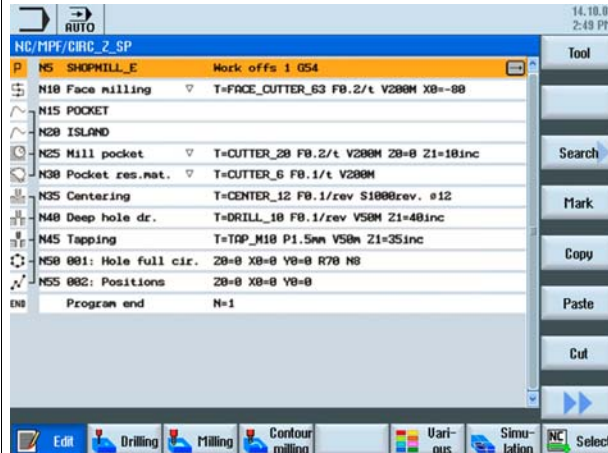

Processes such as drilling, centering, plunging or pocket milling are represented as machining steps in a simple and clear manner. In this way, part programs – even for complex machining operations – are very compact and easily read. Associated sequences are automatically interlinked and can be assigned any position patterns. This unique programming convenience allows you to achieve the shortest programming times even for highly demanding machining tasks.

Master-slave for drives, basic
 Option S52
 Article No.:
 6FC5800-OAS52-OYB0

(6FC5800-OAM03-OYB0
 for V 2.x)

Coupling: "OPEN"

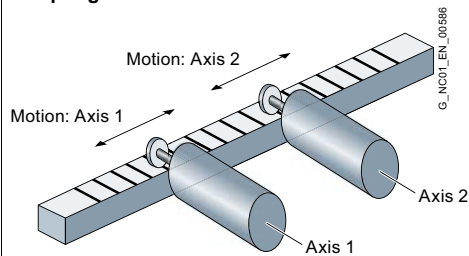

A master-slave coupling is a speed setpoint coupling between a master and slave axis performed at the position controller level – with and without torque equalization control. The coupling can be permanently closed.

Possible applications of a master-slave coupling include:

- Increase the power for mechanically coupled drives
- Compensating gear and gear tooth flank play by entering a pre-tensioning torque

Measure kinematics
 Option P18
 Article No.:
 6FC5800-OAP18-OYB0

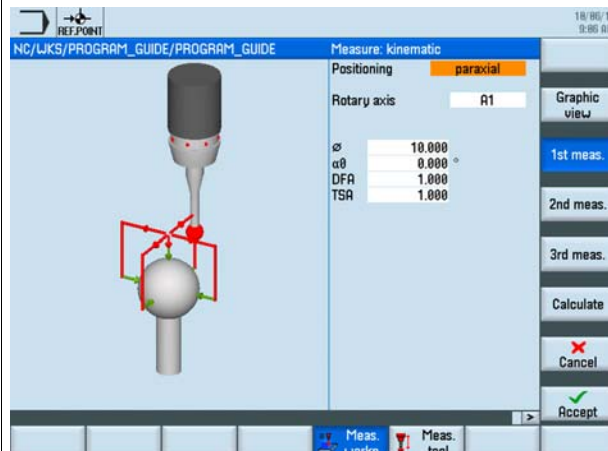

This option is able to determine the parameters of kinematic transformations of the digitally or manually alignable rotary axes quickly and automatically. The function is ideal for initial startup, because a dimensioned drawing of the machine is not required. The function can also be used for regular checking of the production process, when high precision is required.

Measuring cycles for drilling/milling and turning

Option
Article No.:
6FC5800-0AP28-0YB0

Measuring cycles are subroutines designed to perform specific measurement tasks. They can be adapted to specific requirements via parameter settings.

Workpiece measurements

Example: Milling machine

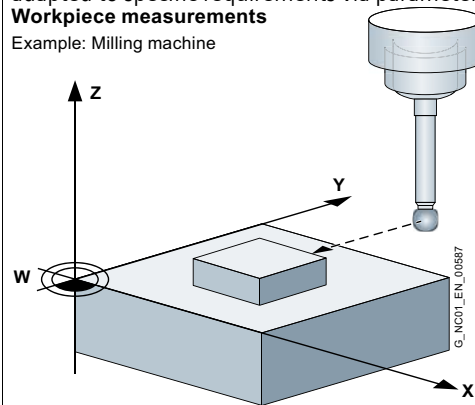

Workpiece measurement

A measuring probe is moved up to the clamped workpiece in the same way as a tool and measured values are acquired. The flexibility of measuring cycles makes it possible to perform nearly all measurements required on a milling or turning machine. An automatic tool offset or zero offset correction can be applied to the workpiece measurement result.

Tool measurements

Measure turning tool length 1, length 2

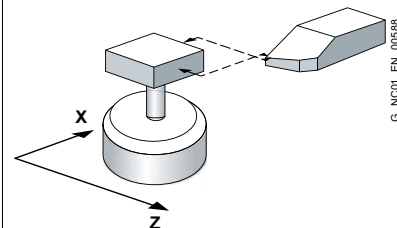

Tool measurement

The selected tool is moved up to the probe and the measured values are acquired. The probe is either in a fixed position or is swung into the working area with a mechanism. The tool geometry measured is entered in the appropriate tool offset data set.

Multiple clamping of various workpieces (included in ShopMill/ShopTurn)

Option P17
Article No.:
6FC5800-0AP17-0YB0

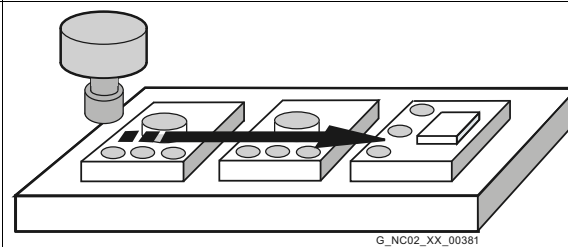

Several identical workpieces can be clamped onto the machine table. With the multiple clamping function, an entire program is generated from the graphic program of the relevant single machining operation. The machining steps are sorted in this program so that the number of tool changes (and thus idle times) is reduced to a minimum.

This function allows different workpieces to be finished on multiple vises or gripping yokes, while saving time.

Note:

Since SW V4.5 multiple clamping (6FC5800-0AP14-0YB0) is part of ShopMill/ShopTurn (6FC5800-0AP17-0YB0).

Glossary

Functions and terms

SINUMERIK 828

Pair of synchronized axes (gantry axes), basic

Option S51
Article No.:
6FC5800-0AS51-0YB0

(Option M02
Article No.:
6FC5800-0AM02-0YB0
for V 2.x)

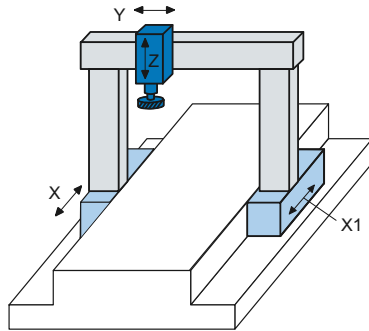

G_NC01_XX_00112

Gantry axes (pair of synchronous axes X/X1)

The gantry axes function can be used to traverse mechanically-coupled axes simultaneously without mechanical offset. The actual values are continuously compared and even the smallest deviations corrected.

During both operation and programming, the axes defined in a gantry grouping are treated like one machine axis.

A maximum of one gantry pair is possible with this option.

Positioning axis/auxiliary spindle, each additional

Option
Article No.:
6FC5800-0AC30-0YB0

(6FC5800-0AB00-0YB0
for V 2.x)

This is an option for any positioning axis that is required in addition to the basic quantity of axes/spindles. The total number of axes/spindles is limited by the maximum number of axes offered by the SINUMERIK 828D family.

Please refer to the table below for the maximum number of axes/spindles offered by all the PPU variants.

→ [Axis/spindle, each additional](#)

Application examples:

For applications like magazine of ATC, pallet, auxiliary spindle (without tapping/threading), or any positioning axis.

Program management on network drive

Option
Article No.:
6FC5800-0AP01-0YB0

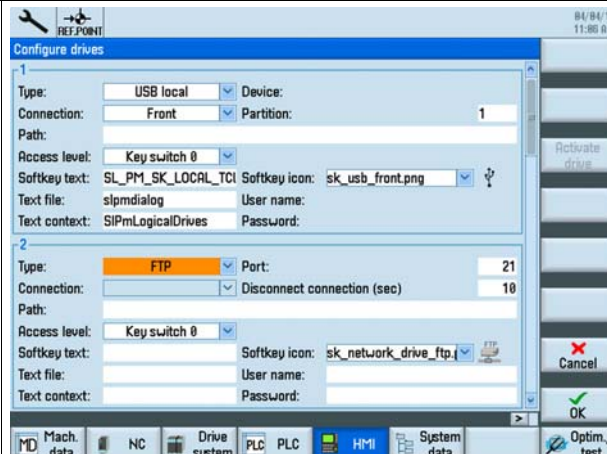

- Allows execution of part-programs from external server by Windows Share/FTP client
- Max 4 additional drives can be defined on Ethernet
- Part program execution can be done from any of these network drives
- Program/workpiece data management can also be done

Replacement tools for tool management

Option M78
Article No.:
6FC5800-0AM78-0YB0

Loc	Type	Tool name	ST	D	H	Length	∅	Tip angle
1	U	KUGEL_D6	1	1	6	97.916	6.000	2
1	U	SPIBO_D8_5	1	1	8	110.632	8.500	118.0
2	U	12MM BALL NOSE	1	1	0	77.540	12.000	2
3	U	1	1	1	0	0.000	0.000	0
4	U	10	1	1	0	0.000	0.000	0
5	U	3D_TASTER	1	1	18	180.914	0.000	0
6	U	SPINDLE	1	1	0	0.000	0.000	0
7	U	T2	1	1	0	0.000	0.000	0
8	U	T3	1	1	0	0.000	0.000	0
9	U	ECA_B_3_12_SF_D12	2	1	10	102.980	12.000	2
10	U	18 MM END MILL	1	1	0	101.124	18.000	4
11	U	CUTTER_10	1	1	0	0.000	10.000	20
12	U	HCD080_ENTGR_45GR	1	1	17	94.657	4.000	90.0
13	U	FRCT100E22_SF_N_D11	2	1	9	93.556	10.000	2
14	U	GEW_FR_ST1_5	1	1	16	108.785	11.800	1
15								

Option for defining replacement sister-tool. Tool life is monitored on the basis of machining time or number of components. If the tool life is completed (or if the tool finishes number of components) the defined sister-tool is automatically selected.

Residual material detection

Option P13
Article No.:
6FC5800-0AP13-0YB0

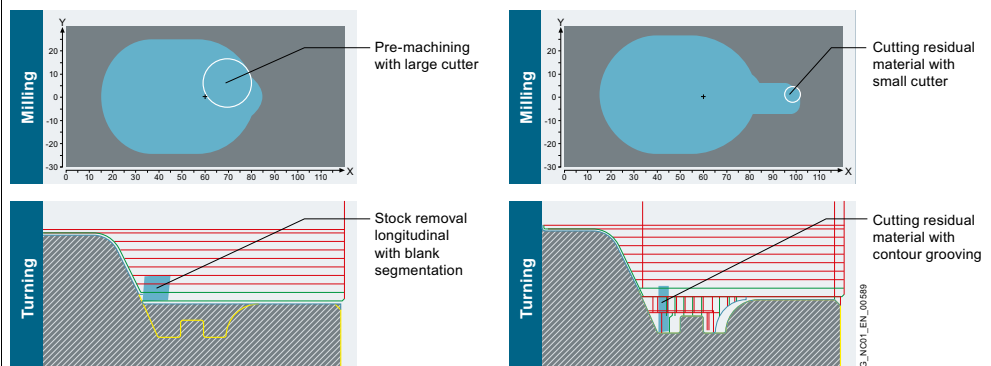

Contour ranges which cannot be machined with large tools are automatically recognized by the cycle for contour pockets or the stock removal cycle. The operator can rework these regions using a smaller tool.

Contour turning offers:

- Contour/axis-parallel cutting with residual material detection
- Contour cutting with residual material detection
- Plunge-turning with residual material detection

Contour milling offers:

- Contour spigot with residual material detection
- Contour pocket with residual material detection
- Machining, e.g. in the steps: centering, predrilling, rough machining and rough machining residual material, smoothing, edge/base, gripping

Glossary

Functions and terms

SINUMERIK 828

Safety Integrated Extended Functions

Option C50
Article No.:
6FC5800-0AC50-0YB0

(6SL3074-0AA10-0AA0
for V 2.x)

SINUMERIK 828 has as standard the following Safety Integrated functions:

- Safe Torque Off (STO)
 - Safe Brake Control (SBS)
 - Safe Stop 1 (SS1)
- Option for extended Safety Integrated Functions for one CNC axis
- Safe Operating Stop (SOS)
 - Safe Stop 2 (SS2)
 - Safely Limited Speed (SLS)
 - Safe Speed Monitor (SSM)
 - Safe Acceleration Monitor (SAM)
 - Safe Direction

SINAMICS S120 Terminal Module Cabinet TM54F is required to configure the above options.

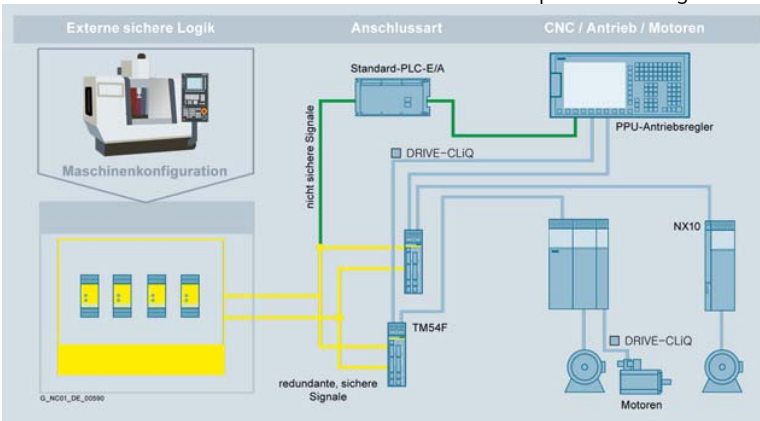

Sag compensation, multi-dimensional

Option M55
Article No.:
6FC5800-0AM55-0YB0

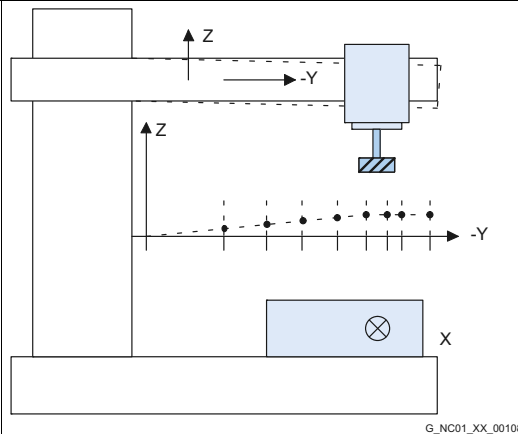

Sag compensation

Multi-dimensional compensation is also possible for the effects of physical influences and manufacturing tolerances such as sag or leadscrew pitch errors. The compensation tables can be switched from the PLC.

When the reference axis and the compensating axis are identical, leadscrew pitch errors can be compensated. By transferring weighting factors (PLC interface), stored compensating characteristics can be adapted to different conditions (e.g.: tools).

The most important features of interpolation and compensation using tables are as follows:

- Independent error characteristics can be defined, in number twice the maximum number of axes
- Freely selectable compensating positions, the number of which is configurable (dependent on the configuration of CNC user memory)
- Interpolating inclusion of the compensation values
- Weighting factor for compensation of tool weights
- Reference axis and compensating axis are selectable

Simultaneous recording
 Option P22
 Article No.:
 6FC5800-0AP22-0YB0

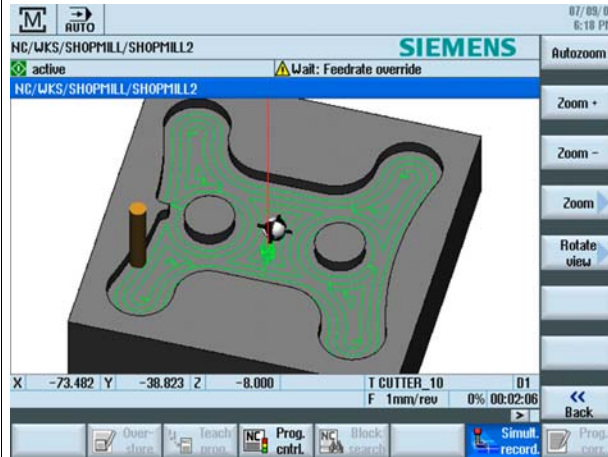

With real-time simulation, the simulation can be viewed in the 'machine' screen of control the when the part program is running in automatic mode. The tool movement in the simulation screen is dependent on the actual tool (axes) movement and gives an accurate view of the machining going on.

Note:

Activate simultaneous recording prior to CNC start in order to avoid incomplete displays.

Glossary

Functions and terms

SINUMERIK 828

**SINUMERIK Integrate
Run MyScreens**
Option P64
Article No.:
6FC5800-0AP64-0YB0

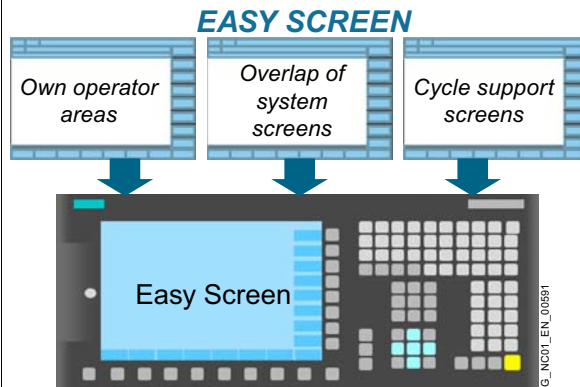

The Easy Screen functionality allows SINUMERIK users to design their own user interfaces for the purpose of displaying either machine-manufacturer or end-user-specific functional expansions or simply their own screen form layouts.

User interfaces configured by Siemens or other machine manufacturers can be modified or replaced. This function is implemented via an integrated interpreter and via configuring files containing the description of the user interface.

The screen forms can be designed directly on the control itself. A graphic tool is required to create graphics and pictures. Part programs can be processed with newly created user interfaces. Configuring examples for new screen forms, which can also be used as the basis for the user's own new screen forms, can be found in the supplied toolbox.

The following functions can be implemented using Easy Screen:

- Display screen forms and provide softkeys, variables, tables, texts, help texts, graphics, and help screens
- Start actions when screen forms are displayed and exited, press softkeys, and enter values (variables)
- Dynamic restructuring of screen forms, including changing softkeys, designing arrays and displaying, replacing and deleting display texts and graphics
- Read and write variables, combine with mathematical, comparative or logical operators
- Execute subprograms, file functions, program instance services (PI services) or external functions (HMI-Advanced)
- Enable data exchange between screen forms
- Easy Screen is configured using ASCII files that can be stored on the PCU. Files that contain ASCII descriptions for the layout of interactive screen forms, softkey functions and display texts and graphics are interpreted. These configuring files are created with the ASCII editor, taking into account certain special rules of syntax.

The user interface can be expanded even in the basic version by up to 5 screen forms via predefined softkeys with the integrated editor.

More than 5 screen forms with Operate Runtime license OA Easy Screen (option P64).

**SINUMERIK Operate
Runtime license OA
Easy Screen**

→ [SINUMERIK Integrate Run MyScreens](#)

Spline interpolation (A, B and C splines)

Option S16
Article No.:
6FC5800-0AS16-0YB0

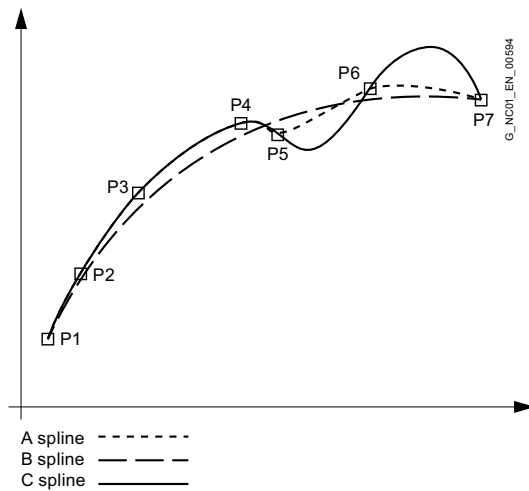

Using spline interpolation, it is possible to obtain a very smooth curve from just a few defined interpolation points along a set contour. The intermediate points are connected by polynomials. The compressor converts linear motions (e.g.: from CAD) at block transitions to splines of constant speed (COMPON) or splines of constant acceleration (COMPCURV). This yields soft transitions that reduce wear on the mechanical parts of the machine tool. However, if the intermediate points are placed close together, quite sharp edges can also be programmed. Spline interpolation also considerably reduces the number of program blocks required.

Extremely smooth workpiece surfaces are often very important in mold and tool making, both optically and technologically, e.g.: for rubber gaskets.

Tool radius compensation is also possible in spline interpolation, as it is in linear or circular interpolation.

Every polynomial can represent a spline. Only the algorithm determines the type of spline.

- A spline is only true to the tangents.
- B spline is true to the tangents and the curvature, but does not run through the nodes (intermediate points).
- C spline is true to the tangents and the curvature and runs through the nodes.

With the COMPCAD compressor, smooth curves of this kind can be approximated within the boundaries of compressor tolerance (parallel tool paths) so that surfaces of a high optical quality can also be obtained in the case of increased tolerances.

Spline interpolation for 3-axis machining is suitable for simple applications and for the JobShop area.

Glossary

Functions and terms

SINUMERIK 828

TRANSMIT/cylinder surface transformation
 Option M27
 Article No.:
 6FC5800-0AM27-0YB0

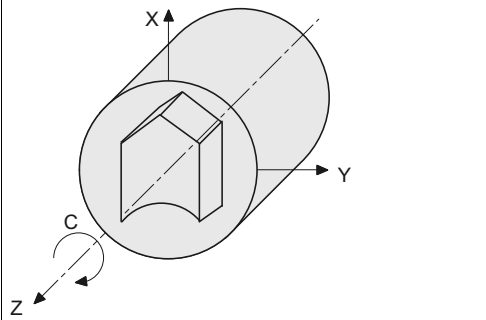

G_NC01_XX_00127

Face machining with TRANSMIT

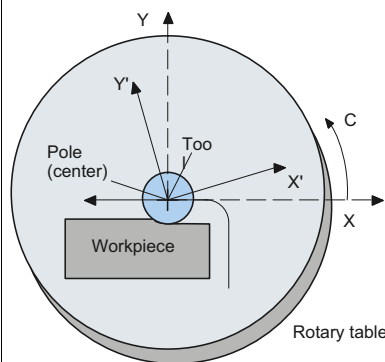

G_NC01_en_00128

Tool-center-point path through the pole

TRANSMIT is used for milling outside contours on turned parts, e.g.: square parts (linear axis with rotary axis).

As a result, programs become much simpler and complete machining increases machine efficiency. Turning and milling can be performed on one machine without rechucking.

3D interpolation with 2 linear axes and one rotary axis is possible. The two linear axes are mutually perpendicular and the rotary axis lies at right angles to one of the linear axes.

TRANSMIT can be called up in different channels simultaneously. The function can be selected and deselected with a preparatory function (straight line, helix, polynomial and activating tool radius compensation) in the part program or MDI.

With TRANSMIT, the area of the transformation pole is reached when the tool center can be positioned at least to the turning center of the rotary axis entering the transformation.

TRANSMIT through the pole is implemented in different ways:

- When traveling through the pole, the rotary axis is turned automatically by 180° when the turning center is reached and the remaining block is then executed.
- When traveling close by the pole, the control automatically reduces the feedrate and the path acceleration.
- If the path contains a corner in the pole, the position jump in the rotary axis is compensated by the control through automatic block insertion.

Cylinder surface transformation is used on turning machines and milling machines, and enables cylinder surface transformation, e.g.: for turned parts.

The TRACYL cylinder surface transformation can be used to manufacture grooves of any shape on the surface of cylindrical bodies with or without groove side offset. The shape of the grooves is programmed in reference to the plane cylinder surface processed.

TRANSMIT/cylinder surface transformation without Y axis
 Option S50
 Article No.:
 6FC5800-0A550-0YB0

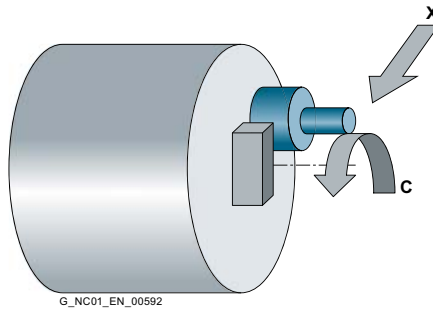

This option – similarly to TRANSMIT and cylinder surface transformation on a cylindrical component – enables to perform front face machining using Cartesian coordinate system and TRACYIL to perform machining on the surface of the cylinder, when physically Y axis is not required.

Travel to fixed stop with Force Control
 Option M01
 Article No.:
 6FC5800-0AM01-0YB0

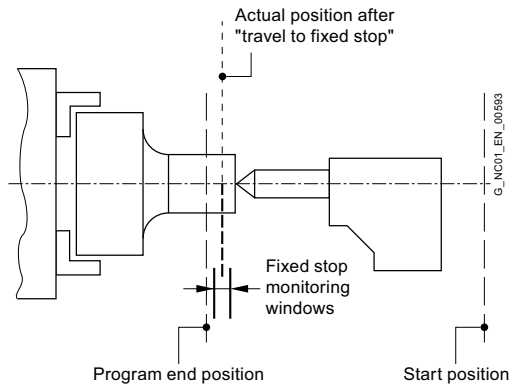

The extended travel to fixed stop function can be used to adapt torque or force on a modal or non-modal basis; travel with limited torque/limited force (force control, FOC) can be initiated, or synchronized actions can be used at any time to program traversing functions.

Application example:

Servo tail stock function with force control requirement. This also can be combined along with synchronized actions.